



TransTig 800 Job
TransTig 2200 Job
TransTig 2500 / 3000 Job
TransTig 4000 / 5000 Job
MagicWave 1700 / 2200 Job
MagicWave 2500 / 3000 Job
MagicWave 4000 / 5000 Job

Operating Instructions

EN

TIG Power source

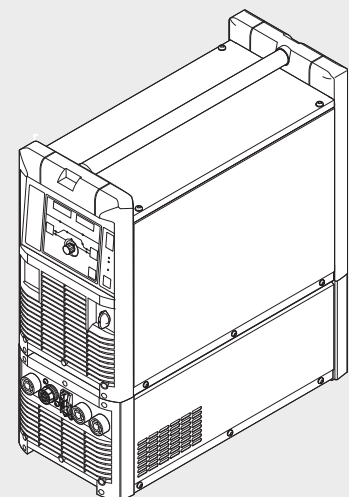

42,0426,0025,EN 020-11052020

Contents

Safety rules	7
Explanation of safety notices	7
General	7
Proper use	7
Environmental conditions	8
Obligations of the operator	8
Obligations of personnel	8
Mains connection	8
Protecting yourself and others	9
Noise emission values	9
Danger from toxic gases and vapours	10
Danger from flying sparks	10
Risks from mains current and welding current	11
Meandering welding currents	12
EMC Device Classifications	12
EMC measures	12
EMF measures	13
Specific hazards	13
Requirement for the shielding gas	14
Danger from shielding gas cylinders	14
Danger from escaping shielding gas	15
Safety measures at the installation location and during transport	15
Safety measures in normal operation	16
Commissioning, maintenance and repair	16
Safety inspection	16
Disposal	17
Safety symbols	17
Data protection	17
Copyright	17
General information	19
General	21
Device concept	21
Functional principle	22
Application areas	22
Warning notices on the device	23
System components	24
General	24
Overview	24
Control elements and connections	25
Description of the control panels	27
General	27
Safety	27
Overview	28
MagicWave control panel	29
MagicWave control panel	29
TransTig control panel	34
TransTig control panel	34
Key combinations - special functions	39
General	39
Keylock	39
Displaying the software version, operating time and coolant flow	39
Connections, switches and mechanical components	40
MagicWave1700 / 2200 Job	40
MagicWave2500 / 3000 Job	41
MagicWave4000 / 5000 Job	42
TransTig800 / 2200 Job	43

TransTig2500 / 3000 Job	44
TransTig4000 / 5000 Job	45

Installation and commissioning 47

Minimum equipment needed for welding task	49
General	49
TIG AC welding	49
TIG DC welding	49
Automated TIG welding	49
MMA welding	49
Before installation and commissioning	50
Safety	50
Utilisation for intended purpose	50
Setup regulations	50
Mains connection	50
Generator-powered operation (MW 1700 / 2200, TT 800 / 2200)	51
Connecting up the mains cable on US power sources	52
General	52
Stipulated mains cables and strain-relief devices	52
Safety	52
Connecting the mains cable	52
Replacing the strain-relief device	53
Start-up	55
Safety	55
Remarks on the cooling unit	55
General	55
Connecting the gas cylinder	55
Establishing a ground (earth) connection to the workpiece	56
Connecting the welding torch	56

Welding 57

TIG modes	59
Safety	59
Symbols and their explanations	59
2-step mode	60
Spot welding	61
4-step mode	62
Special 4-step mode: variant 1	63
Special 4-step mode: variant 2	63
Special 4-step mode: variant 3	64
Special 4-step mode: variant 4	64
Special 4-step mode: variant 5	65
Special 4-step mode: variant 6	65
Cap shaping and cap overloading	67
Cap-shaping	67
Cap overloading	67
TIG welding	68
Safety	68
Welding parameters	68
Preparation	70
TIG welding	70
Igniting the arc	72
General	72
Igniting the arc using high frequency(HF ignition)	72
Touchdown ignition	73
End of welding	74
Special functions and options	75
Arc break watchdog function	75
Ignition time-out function	75
TIG pulsing	75
Tacking function	76
TIG cold-wire welding	77

MMA welding	79
Safety	79
Preparation	79
MMA welding	79
Hotstart function.....	80
Anti-stick function.....	81
Job mode	82
General	82
Abbreviations	82
Saving a job	82
Retrieving a job.....	83
Retrieving jobs on the JobMaster TIG	83
Copying/overwriting a job.....	84
Deleting a job.....	85

Setup settings 87

Job correction	89
General	89
Opening the Job correction menu.....	89
Changing welding parameters	89
Exiting the Job correction menu.....	89
Welding parameters that can be corrected in the Job correction menu.....	89
The Setup menu	95
General	95
Overview	95
Shielding gas setup menu.....	96
General	96
Opening the Protective gas shield set-up menu	96
Changing welding parameters	96
Exiting the set-up menu	96
Welding parameters in the Protective gas shield set-up menu.....	96
TIG setup menu	98
Opening the TIG set-up menu	98
Changing welding parameters	98
Exiting the set-up menu	98
Welding parameters in the TIG set-up menu.....	98
TIG setup menu: level 2.....	102
Opening the TIG set-up menu: level 2.....	102
Changing welding parameters	102
Exiting the TIG set-up menu: level 2.....	102
Welding parameters in the TIG setup menu - level 2.....	102
AC/polarity reversal set-up menu.....	107
General	107
Opening the AC/polarity reversal set-up menu.....	107
Changing welding parameters	107
Exiting the set-up menu	107
Welding parameters in the AC/polarity reversal set-up menu.....	107
AC/polarity reversal set-up menu - level 2	109
General	109
Opening the AC/polarity reversal set-up menu - level 2	109
Changing welding parameters	109
Exiting from the AC/polarity reversal set-up menu - level 2.....	109
Welding parameters in the AC/polarity reversal set-up menu - level 2.....	109
DC set-up menu	111
General	111
Opening the DC set-up menu	111
Changing welding parameters	111
Exiting the set-up menu	111
Welding parameters in the DC set-up menu.....	111
DC set-up menu - level 2	112
General	112
Opening the DC set-up menu - level 2.....	112
Changing welding parameters	112

Exiting from the DC set-up menu - level 2	112
Welding parameters in the DC set-up menu - level 2	112
Rod electrode setup menu	113
Opening the rod electrode set-up menu	113
Changing welding parameters	113
Exiting the set-up menu	113
Welding parameters in the rod electrode set-up menu	113
Rod electrode setup menu: level 2	115
Opening the rod electrode set-up menu level 2	115
Changing welding parameters	115
Exiting the rod electrode set-up menu - level 2.....	115
Welding parameters in the rod electrode setup menu - level 2.....	115
Measuring welding circuit resistance r	119
General	119
Measuring the welding circuit resistance r	119
Displaying welding circuit inductivity L	120
General information on welding circuit inductivity L	120
Displaying welding circuit inductivity L	120

Troubleshooting and maintenance **121**

Troubleshooting	123
General	123
Safety	123
Displayed service codes	123
Power source - troubleshooting	127
Care, maintenance and disposal	129
General	129
Safety	129
At every start-up.....	129
Every 2 months	129
Every 6 months	130
Disposal	130

Appendix **131**

Technical data.....	133
Special voltages.....	133
MagicWave1700 / 2200 Job	133
MagicWave2500 / 3000 Job	134
MagicWave 2500 / 3000 Job MV	134
MagicWave4000 / 5000 Job	135
MagicWave 4000 / 5000 Job MV	136
TransTig800 / 2200 Job	137
TransTig2500 / 3000 Job	138
TransTig 2500 / 3000 Job MV.....	139
TransTig4000 / 5000 Job	140
TransTig 4000 / 5000 Job MV.....	141
Explanation of footnotes	141
Terms and abbreviations used.....	142
General	142
Terms and abbreviations A - C	142
Terms and abbreviations D - E	142
Terms and abbreviations F	143
Terms and abbreviations G - H.....	143
Terms and abbreviations I - P.....	144
Terms and abbreviations R - 2nd.....	144

Safety rules

Explanation of safety notices



DANGER!

Indicates immediate danger.

- ▶ If not avoided, death or serious injury will result.



WARNING!

Indicates a potentially hazardous situation.

- ▶ If not avoided, death or serious injury may result.



CAUTION!

Indicates a situation where damage or injury could occur.

- ▶ If not avoided, minor injury and/or damage to property may result.

NOTE!

Indicates a risk of flawed results and possible damage to the equipment.

General

The device is manufactured using state-of-the-art technology and according to recognised safety standards. If used incorrectly or misused, however, it can cause:

- injury or death to the operator or a third party,
- damage to the device and other material assets belonging to the operating company,
- inefficient operation of the device.

All persons involved in commissioning, operating, maintaining and servicing the device must:

- be suitably qualified,
- have sufficient knowledge of welding and
- read and follow these operating instructions carefully.

The operating instructions must always be at hand wherever the device is being used. In addition to the operating instructions, attention must also be paid to any generally applicable and local regulations regarding accident prevention and environmental protection.

All safety and danger notices on the device

- must be in a legible state,
- must not be damaged,
- must not be removed,
- must not be covered, pasted or painted over.

For the location of the safety and danger notices on the device, refer to the section headed "General" in the operating instructions for the device.

Before switching on the device, rectify any faults that could compromise safety.

This is for your personal safety!

Proper use

The device is to be used exclusively for its intended purpose.

The device is intended solely for the welding processes specified on the rating plate. Any use above and beyond this purpose is deemed improper. The manufacturer shall not be held liable for any damage arising from such usage.

Proper use includes:

- carefully reading and following all the instructions given in the operating instructions
 - studying and obeying all safety and danger notices carefully
 - performing all stipulated inspection and maintenance work.
-

Never use the device for the following purposes:

- Thawing out pipes
 - Charging batteries
 - Starting engines
-

The device is designed for use in industry and the workshop. The manufacturer accepts no responsibility for any damage caused through use in a domestic setting.

The manufacturer likewise accepts no liability for inadequate or incorrect results.

Environmental conditions

Operation or storage of the device outside the stipulated area will be deemed as not in accordance with the intended purpose. The manufacturer shall not be held liable for any damage arising from such usage.

Ambient temperature range:

- during operation: -10 °C to + 40 °C (14 °F to 104 °F)
 - during transport and storage: -20 °C to +55 °C (-4 °F to 131 °F)
-

Relative humidity:

- up to 50% at 40 °C (104 °F)
 - up to 90% at 20 °C (68 °F)
-

The surrounding air must be free from dust, acids, corrosive gases or substances, etc. Can be used at altitudes of up to 2000 m (6561 ft. 8.16 in.)

Obligations of the operator

The operator must only allow persons to work with the device who:

- are familiar with the fundamental instructions regarding safety at work and accident prevention and have been instructed in how to use the device
 - have read and understood these operating instructions, especially the section "safety rules", and have confirmed as much with their signatures
 - are trained to produce the required results.
-

Checks must be carried out at regular intervals to ensure that operators are working in a safety-conscious manner.

Obligations of personnel

Before using the device, all persons instructed to do so undertake:

- to observe the basic instructions regarding safety at work and accident prevention
 - to read these operating instructions, especially the "Safety rules" section and sign to confirm that they have understood them and will follow them.
-

Before leaving the workplace, ensure that people or property cannot come to any harm in your absence.

Mains connection

Devices with a higher rating may affect the energy quality of the mains due to their current consumption.

This may affect a number device types in terms of:

- Connection restrictions
- Criteria with regard to the maximum permissible mains impedance ^{*)}
- Criteria with regard to the minimum short-circuit power requirement ^{*)}

^{*)} at the interface with the public grid
see "Technical data"

In this case, the plant operator or the person using the device should check whether the device may be connected, where appropriate by discussing the matter with the power supply company.

IMPORTANT! Ensure that the mains connection is earthed properly

Protecting yourself and others

Anyone working with the device exposes themselves to numerous risks, e.g.

- flying sparks and hot pieces of metal
- Arc radiation, which can damage eyes and skin
- Hazardous electromagnetic fields, which can endanger the lives of those using cardiac pacemakers
- Risk of electrocution from mains current and welding current
- Greater noise pollution
- Harmful welding fumes and gases

Suitable protective clothing must be worn when working with the device. The protective clothing must have the following properties:

- Flame-resistant
- Insulating and dry
- Covers the whole body, is undamaged and in good condition
- Safety helmet
- Trousers with no turn-ups

Protective clothing refers to a variety of different items. Operators should:

- Protect eyes and face from UV rays, heat and sparks using a protective visor and regulation filter
- Wear regulation protective goggles with side protection behind the protective visor
- Wear stout footwear that provides insulation even in wet conditions
- Protect the hands with suitable gloves (electrically insulated and providing protection against heat)
- Wear ear protection to reduce the harmful effects of noise and to prevent injury

Keep all persons, especially children, out of the working area while any devices are in operation or welding is in progress. If, however, there are people in the vicinity:

- Make them aware of all the dangers (risk of dazzling by the arc, injury from flying sparks, harmful welding fumes, noise, possible risks from mains current and welding current, etc.)
- Provide suitable protective equipment
- Alternatively, erect suitable safety screens/curtains.

Noise emission values

The device generates a maximum sound power level of <80 dB(A) (ref. 1pW) when idling and in the cooling phase following operation at the maximum permissible operating point under maximum rated load conditions according to EN 60974-1.

It is not possible to provide a workplace-related emission value during welding (or cutting) as this is influenced by both the process and the environment. All manner of different welding parameters come into play, including the welding process (MIG/MAG, TIG welding), the type of power selected (DC or AC), the power range, the type of weld metal, the resonance characteristics of the workpiece, the workplace environment, etc.

Danger from toxic gases and vapours

The fumes produced during welding contain harmful gases and vapours.

Welding fumes contain substances that cause cancer, as stated in Monograph 118 of the International Agency for Research on Cancer.

Use at-source extraction and a room extraction system.
If necessary, use a welding torch with an integrated extraction device.

Keep your face away from welding fumes and gases.

Fumes and hazardous gases

- must not be breathed in
- must be extracted from the working area using appropriate methods.

Ensure an adequate supply of fresh air. Ensure that there is a ventilation rate of at least 20 m³ per hour at all times.

Otherwise, a welding helmet with an air supply must be worn.

If there is any doubt about whether the extraction capacity is sufficient, the measured toxic emission values should be compared with the permissible limit values.

The following components are responsible, amongst other things, for the degree of toxicity of welding fumes:

- Metals used for the workpiece
- Electrodes
- Coatings
- Cleaners, degreasers, etc.
- Welding process used

The relevant material safety data sheets and manufacturer's specifications for the listed components should therefore be studied carefully.

Recommendations for trade fair scenarios, risk management measures and for identifying working conditions can be found on the European Welding Association website under Health & Safety (<https://european-welding.org>).

Flammable vapours (e.g. solvent fumes) should be kept away from the arc's radiation area.

Close the shielding gas cylinder valve or main gas supply if no welding is taking place.

Danger from flying sparks

Flying sparks may cause fires or explosions.

Never weld close to flammable materials.

Flammable materials must be at least 11 metres (36 ft. 1.07 in.) away from the arc, or alternatively covered with an approved cover.

A suitable, tested fire extinguisher must be available and ready for use.

Sparks and pieces of hot metal may also get into adjacent areas through small gaps or openings. Take appropriate precautions to prevent any danger of injury or fire.

Welding must not be performed in areas that are subject to fire or explosion or near sealed tanks, vessels or pipes unless these have been prepared in accordance with the relevant national and international standards.

Do not carry out welding on containers that are being or have been used to store gases, propellants, mineral oils or similar products. Residues pose an explosive hazard.

Risks from mains current and welding current

An electric shock is potentially life threatening and can be fatal.

Do not touch live parts either inside or outside the device.

During MIG/MAG welding and TIG welding, the welding wire, the wirespool, the feed rollers and all pieces of metal that are in contact with the welding wire are live.

Always set the wirefeeder up on a sufficiently insulated surface or use a suitable, insulated wirefeeder holder.

Make sure that you and others are protected with an adequately insulated, dry base or cover for the earth or ground potential. This base or cover must extend over the entire area between the body and the earth or ground potential.

All cables and leads must be secured, undamaged, insulated and adequately dimensioned. Replace loose connections and scorched, damaged, or inadequately dimensioned cables and leads immediately.

Use the handle to ensure the power connections are tight before every use.

In the case of power cables with a bayonet connector, rotate the power cable around the longitudinal axis by at least 180° and pretension.

Do not wrap cables or leads around the body or parts of the body.

The electrode (rod electrode, tungsten electrode, welding wire, etc.) must

- never be immersed in liquid for cooling
- Never touch the electrode when the power source is switched on.

Double the open circuit voltage of a power source can occur between the welding electrodes of two power sources. Touching the potentials of both electrodes at the same time may be fatal under certain circumstances.

Arrange for the mains cable to be checked regularly by a qualified electrician to ensure the ground conductor is functioning properly.

Protection class I devices require a mains supply with ground conductor and a connector system with ground conductor contact for proper operation.

Operation of the device on a mains supply without ground conductor and on a socket without ground conductor contact is only permitted if all national regulations for protective separation are observed.

Otherwise, this is considered gross negligence. The manufacturer shall not be held liable for any damage arising from such usage.

If necessary, provide adequate earthing for the workpiece.

Switch off unused devices.

Wear a safety harness if working at height.

Before working on the device, switch it off and pull out the mains plug.

Attach a clearly legible and easy-to-understand warning sign to the device to prevent anyone from plugging the mains plug back in and switching it on again.

After opening the device:

- Discharge all live components
- Ensure that all components in the device are de-energised.

If work on live parts is required, appoint a second person to switch off the main switch at the right moment.

Meandering welding currents

If the following instructions are ignored, meandering welding currents can develop with the following consequences:

- Fire hazard
- Overheating of parts connected to the workpiece
- Irreparable damage to ground conductors
- Damage to device and other electrical equipment

Ensure that the workpiece is held securely by the workpiece clamp.

Attach the workpiece clamp as close as possible to the area that is to be welded.

Position the device with sufficient insulation against electrically conductive environments, e.g. Insulation against conductive floor or insulation to conductive racks.

If distribution boards, twin-head mounts, etc., are being used, note the following: The electrode of the welding torch / electrode holder that is not used is also live. Make sure that the welding torch / electrode holder that is not used is kept sufficiently insulated.

In the case of automated MIG/MAG applications, ensure that only an insulated wire electrode is routed from the welding wire drum, large wirefeeder spool or wirepool to the wirefeeder.

EMC Device Classifications

Devices in emission class A:

- Are only designed for use in industrial settings
- Can cause line-bound and radiated interference in other areas

Devices in emission class B:

- Satisfy the emissions criteria for residential and industrial areas. This is also true for residential areas in which the energy is supplied from the public low-voltage mains.

EMC device classification as per the rating plate or technical data.

EMC measures

In certain cases, even though a device complies with the standard limit values for emissions, it may affect the application area for which it was designed (e.g. when there is sensitive equipment at the same location, or if the site where the device is installed is close to either radio or television receivers).

If this is the case, then the operator is obliged to take appropriate action to rectify the situation.

Check and evaluate the immunity to interference of nearby devices according to national and international regulations. Examples of equipment that may be susceptible to interference from the device include:

- Safety devices
 - Power, signal and data transfer lines
 - IT and telecommunications devices
 - Measuring and calibrating devices
-

Supporting measures for avoidance of EMC problems:

1. Mains supply
 - If electromagnetic interference arises despite correct mains connection, additional measures are necessary (e.g. use a suitable line filter).
2. Welding power leads
 - must be kept as short as possible
 - must run close together (to avoid EMF problems)
 - must be kept well apart from other leads
3. Equipotential bonding
4. Earthing of the workpiece
 - If necessary, establish an earth connection using suitable capacitors.
5. Shielding, if necessary
 - Shield off other nearby devices
 - Shield off entire welding installation

EMF measures

Electromagnetic fields may pose as yet unknown risks to health:

- effects on the health of others in the vicinity, e.g. wearers of pacemakers and hearing aids
- wearers of pacemakers must seek advice from their doctor before approaching the device or any welding that is in progress
- for safety reasons, keep distances between the welding cables and the welder's head/torso as large as possible
- do not carry welding cables and hosepacks over the shoulders or wind them around any part of the body

Specific hazards

Keep hands, hair, clothing and tools away from moving parts. For example:

- Fans
- Cogs
- Rollers
- Shafts
- Wirespools and welding wires

Do not reach into the rotating cogs of the wire drive or into rotating drive components.

Covers and side panels may only be opened/removed while maintenance or repair work is being carried out.

During operation

- Ensure that all covers are closed and all side panels are fitted properly.
- Keep all covers and side panels closed.

The welding wire emerging from the welding torch poses a high risk of injury (piercing of the hand, injuries to the face and eyes, etc.).

Therefore always keep the welding torch away from the body (devices with wire-feed unit) and wear suitable protective goggles.

Never touch the workpiece during or after welding - risk of burns.

Slag can jump off cooling workpieces. The specified protective equipment must therefore also be worn when reworking workpieces, and steps must be taken to ensure that other people are also adequately protected.

Welding torches and other parts with a high operating temperature must be allowed to cool down before handling.

Special provisions apply in areas at risk of fire or explosion - observe relevant national and international regulations.

Power sources for work in areas with increased electric risk (e.g. near boilers) must carry the "Safety" sign. However, the power source must not be located in such areas.

Risk of scalding from escaping coolant. Switch off cooling unit before disconnecting coolant flow or return lines.

Observe the information on the coolant safety data sheet when handling coolant. The coolant safety data sheet may be obtained from your service centre or downloaded from the manufacturer's website.

Use only suitable load-carrying equipment supplied by the manufacturer when transporting devices by crane.

- Hook chains and/or ropes onto all suspension points provided on the load-carrying equipment.
 - Chains and ropes must be at the smallest angle possible to the vertical.
 - Remove gas cylinder and wire-feed unit (MIG/MAG and TIG devices).
-

If the wire-feed unit is attached to a crane holder during welding, always use a suitable, insulated wirefeeder hoisting attachment (MIG/MAG and TIG devices).

If the device has a carrying strap or handle, this is intended solely for carrying by hand. The carrying strap is not to be used if transporting with a crane, counterbalanced lift truck or other mechanical hoist.

All lifting accessories (straps, handles, chains, etc.) used in connection with the device or its components must be tested regularly (e.g. for mechanical damage, corrosion or changes caused by other environmental factors).

The testing interval and scope of testing must comply with applicable national standards and directives as a minimum.

Odourless and colourless shielding gas may escape unnoticed if an adapter is used for the shielding gas connection. Prior to assembly, seal the device-side thread of the adapter for the shielding gas connection using suitable Teflon tape.

Requirement for the shielding gas

Especially with ring lines, contaminated shielding gas can cause damage to equipment and reduce welding quality.

Meet the following requirements regarding shielding gas quality:

- Solid particle size < 40 µm
 - Pressure condensation point < -20 °C
 - Max. oil content < 25 mg/m³
-

Use filters if necessary.

Danger from shielding gas cylinders

Shielding gas cylinders contain gas under pressure and can explode if damaged. As the shielding gas cylinders are part of the welding equipment, they must be handled with the greatest of care.

Protect shielding gas cylinders containing compressed gas from excessive heat, mechanical impact, slag, naked flames, sparks and arcs.

Mount the shielding gas cylinders vertically and secure according to instructions to prevent them falling over.

Keep the shielding gas cylinders well away from any welding or other electrical circuits.

Never hang a welding torch on a shielding gas cylinder.

Never touch a shielding gas cylinder with an electrode.

Risk of explosion - never attempt to weld a pressurised shielding gas cylinder.

Only use shielding gas cylinders suitable for the application in hand, along with the correct and appropriate accessories (regulator, hoses and fittings). Only use shielding gas cylinders and accessories that are in good condition.

Turn your face to one side when opening the valve of a shielding gas cylinder.

Close the shielding gas cylinder valve if no welding is taking place.

If the shielding gas cylinder is not connected, leave the valve cap in place on the cylinder.

The manufacturer's instructions must be observed as well as applicable national and international regulations for shielding gas cylinders and accessories.

Danger from escaping shielding gas

Risk of suffocation from the uncontrolled escape of shielding gas

Shielding gas is colourless and odourless and, in the event of a leak, can displace the oxygen in the ambient air.

- Ensure an adequate supply of fresh air with a ventilation rate of at least 20 m³/hour.
- Observe safety and maintenance instructions on the shielding gas cylinder or the main gas supply.
- Close the shielding gas cylinder valve or main gas supply if no welding is taking place.
- Check the shielding gas cylinder or main gas supply for uncontrolled gas leakage before every start-up.

Safety measures at the installation location and during transport

A device toppling over could easily kill someone. Place the device on a solid, level surface such that it remains stable

- The maximum permissible tilt angle is 10°.

Special regulations apply in rooms at risk of fire or explosion

- Observe relevant national and international regulations.

Use internal directives and checks to ensure that the workplace environment is always clean and clearly laid out.

Only set up and operate the device in accordance with the degree of protection shown on the rating plate.

When setting up the device, ensure there is an all-round clearance of 0.5 m (1 ft. 7.69 in.) to ensure that cooling air can flow in and out freely.

When transporting the device, observe the relevant national and local guidelines and accident prevention regulations. This applies especially to guidelines regarding the risks arising during transport.

Do not lift or transport operational devices. Switch off devices before transport or lifting.

Before transporting the device, allow coolant to drain completely and detach the following components:

- Wirefeeder
- Wirespool
- Shielding gas cylinder

After transporting the device, the device must be visually inspected for damage before commissioning. Any damage must be repaired by trained service technicians before commissioning the device.

Safety measures in normal operation

Only operate the device when all safety devices are fully functional. If the safety devices are not fully functional, there is a risk of

- injury or death to the operator or a third party
- damage to the device and other material assets belonging to the operator
- inefficient operation of the device

Any safety devices that are not functioning properly must be repaired before switching on the device.

Never bypass or disable safety devices.

Before switching on the device, ensure that no one is likely to be endangered.

Check the device at least once a week for obvious damage and proper functioning of safety devices.

Always fasten the shielding gas cylinder securely and remove it beforehand if the device is to be transported by crane.

Only the manufacturer's original coolant is suitable for use with our devices due to its properties (electrical conductivity, anti-freeze agent, material compatibility, flammability, etc.).

Only use suitable original coolant from the manufacturer.

Do not mix the manufacturer's original coolant with other coolants.

Only connect the manufacturer's system components to the cooling circuit.

The manufacturer accepts no liability for damage resulting from use of other system components or a different coolant. In addition, all warranty claims will be forfeited.

Cooling Liquid FCL 10/20 does not ignite. The ethanol-based coolant can ignite under certain conditions. Transport the coolant only in its original, sealed containers and keep well away from any sources of ignition.

Used coolant must be disposed of properly in accordance with the relevant national and international regulations. The coolant safety data sheet may be obtained from your service centre or downloaded from the manufacturer's website.

Check the coolant level before starting to weld, while the system is still cool.

Commissioning, maintenance and repair

It is impossible to guarantee that bought-in parts are designed and manufactured to meet the demands made of them, or that they satisfy safety requirements.

- Use only original spare and wearing parts (also applies to standard parts).
- Do not carry out any modifications, alterations, etc. to the device without the manufacturer's consent.
- Components that are not in perfect condition must be replaced immediately.
- When ordering, please give the exact designation and part number as shown in the spare parts list, as well as the serial number of your device.

The housing screws provide the ground conductor connection for earthing the housing parts.

Only use original housing screws in the correct number and tightened to the specified torque.

Safety inspection

The manufacturer recommends that a safety inspection of the device is performed at least once every 12 months.

The manufacturer recommends that the power source be calibrated during the same 12-month period.

A safety inspection should be carried out by a qualified electrician

- after any changes are made
 - after any additional parts are installed, or after any conversions
 - after repair, care and maintenance has been carried out
 - at least every twelve months.
-

For safety inspections, follow the appropriate national and international standards and directives.

Further details on safety inspection and calibration can be obtained from your service centre. They will provide you on request with any documents you may require.

Disposal

Do not dispose of this device with normal domestic waste! To comply with the European Directive on Waste Electrical and Electronic Equipment and its implementation as national law, electrical equipment that has reached the end of its life must be collected separately and returned to an approved recycling facility. Any device that you no longer require must either be returned to your dealer or given to one of the approved collection and recycling facilities in your area. Ignoring this European Directive may have potentially adverse affects on the environment and your health!

Safety symbols

Devices with the CE mark satisfy the essential requirements of the low-voltage and electromagnetic compatibility directives (e.g. relevant product standards of the EN 60 974 series).

Fronius International GmbH hereby declares that the device is compliant with Directive 2014/53/EU. The full text on the EU Declaration of Conformity can be found at the following address: <http://www.fronius.com>

Devices marked with the CSA test mark satisfy the requirements of the relevant standards for Canada and the USA.

Data protection

The user is responsible for the safekeeping of any changes made to the factory settings. The manufacturer accepts no liability for any deleted personal settings.

Copyright

Copyright of these operating instructions remains with the manufacturer.

The text and illustrations are all technically correct at the time of printing. We reserve the right to make changes. The contents of the operating instructions shall not provide the basis for any claims whatsoever on the part of the purchaser. If you have any suggestions for improvement, or can point out any mistakes that you have found in the instructions, we will be most grateful for your comments.

General information

Device concept



TransTig 2200 Job, MagicWave 1700 Job and MagicWave 2200 Job with cooling unit



MagicWave 3000 Job with cooling unit and MagicWave 2500 Job



TransTig 5000 Job and MagicWave 5000 Job, both with cooling unit and trolley

The MagicWave (MW)1700 / 2200 / 2500 / 3000 / 4000 / 5000 and TransTig (TT) 800 / 2200 / 2500 / 3000 / 4000 / 5000 TIG power sources are completely digitised, microprocessor controlled inverter power sources.

Their modular design and potential for system add-ons ensure a high degree of flexibility. The devices can be adapted to any situation.

The straightforward operating concept means that essential functions can be seen at a glance and adjusted as required. Job mode allows frequently used welding data to be stored and retrieved easily.

A standardised LocalNet interface makes it easy to connect digital system add-ons (e.g. JobMaster TIG welding torches, robot welding torches, remote control units, etc.).

Automatic cap-shaping for AC welding with MagicWave power sources takes the diameter of the tungsten electrode into account to help produce optimum results.

The power sources are generator-compatible. They are exceptionally sturdy in day-to-day operation thanks to the protected control elements and their powder-coated housings.

The TIG pulsed arc function, with its wide frequency range, is available on both the MagicWave and TransTig.

To optimise the ignition sequence in TIG AC welding, the MagicWave takes into account not only the diameter of the electrode, but also its current temperature, calculated with reference to the preceding welding time and welding off-time.

RPI (**R**everse **P**olarity **I**gnition) ensures an excellent ignition response during TIG DC welding.

Functional principle

The central control and regulation unit of the power sources is coupled with a digital signal processor. The central control and regulation unit and signal processor control the entire welding process.

During the welding process, the actual data is measured continuously and the device responds immediately to any changes. Control algorithms ensure that the desired target state is maintained.

This results in:

- a precise welding process,
- exact reproducibility of all results
- excellent weld properties.

Application areas

The devices are used in workshops and industry for manual and automated TIG applications with unalloyed and low-alloy steel and high-alloy chrome-nickel steels.

The MagicWave power sources perform exceptionally well when it comes to welding aluminium, aluminium alloys and magnesium due to the variable AC frequency.

Warning notices on the device

US power sources come with extra warning notices affixed to the device. The warning notices must NOT be removed or painted over.

 WARNING			ARC RAYS can burn eyes and skin; NOISE can damage hearing. <ul style="list-style-type: none"> Wear welding helmet with correct filter. Wear correct eye, ear and body protection.
Do not Remove, Destroy, Or Cover This Label			EXPLODING PARTS can injure. <ul style="list-style-type: none"> Failed parts can explode or cause other parts to explode when power is applied. Always wear a face shield and long sleeves when servicing.
ARC WELDING can be hazardous. <ul style="list-style-type: none"> Read and follow all labels and the Owner's Manual carefully Only qualified persons are to install, operate, or service this unit according to all applicable codes and safety practices. Keep children away. Pacemaker wearers keep away. Welding wire and drive parts may be at welding voltage. 			ELECTRIC SHOCK can kill; SIGNIFICANT DC VOLTAGE exists after removal of input power <ul style="list-style-type: none"> Always wait 60 seconds after power is turned off before working on unit. Check input capacitor voltage, and be sure it is near 0 before touching parts.
	ELECTRIC SHOCK can kill. <ul style="list-style-type: none"> Always wear dry insulating gloves. Insulate yourself from work and ground. Do not touch live electrical parts. Disconnect input power before servicing. Keep all panels and covers securely in place. 	 AVERTISSEMENT	
	FUMES AND GASES can be hazardous. <ul style="list-style-type: none"> Keep your head out of the fumes. Ventilate area, or use breathing device. Read Material Safety Data Sheets (MSDSs) and manufacturer's instructions for materials used. 	UN CHOC ELECTRIQUE peut etre mortel. <ul style="list-style-type: none"> Installation et raccordement de cette machine doivent etre conformes a tous les pertinents. SOUDAGE A L'ARC peut etre hasardeux. <ul style="list-style-type: none"> Lire le manuel d' instructions avant utilisation. Ne pas installer sur une surface combustible. Les fils de soudage et pieces conductrices peuvent etre a la tension de soudage. 	
	WELDING can cause fire or explosion. <ul style="list-style-type: none"> Do not weld near flammable material. Watch for fire: keep extinguisher nearby. Do not locate unit over combustible surfaces. Do not weld on closed containers. 		

	
INCORRECT VOLTAGE can cause ELECTRIC SHOCK and DAMAGE to the machine. Read operating instructions.	
 1 ~ 230/240V	



Read American National Standard Z49.1, "Safety In Welding and Cutting" From American Welding Society, 550 N.W. LeJeune Rd., Miami, FL 33126; OSHA Safety and Health Standards, 29 CFR 1910, from U.S. Government Printing Office, Washington, DC 20402. CSA, W117-2 M87 Code for Safety in Welding and Cutting.

US version of power source with additional warning notices, e.g. MagicWave 2200

System components

General

The TransTig and MagicWave power sources can be used with a wide variety of system add-ons and options.

Overview

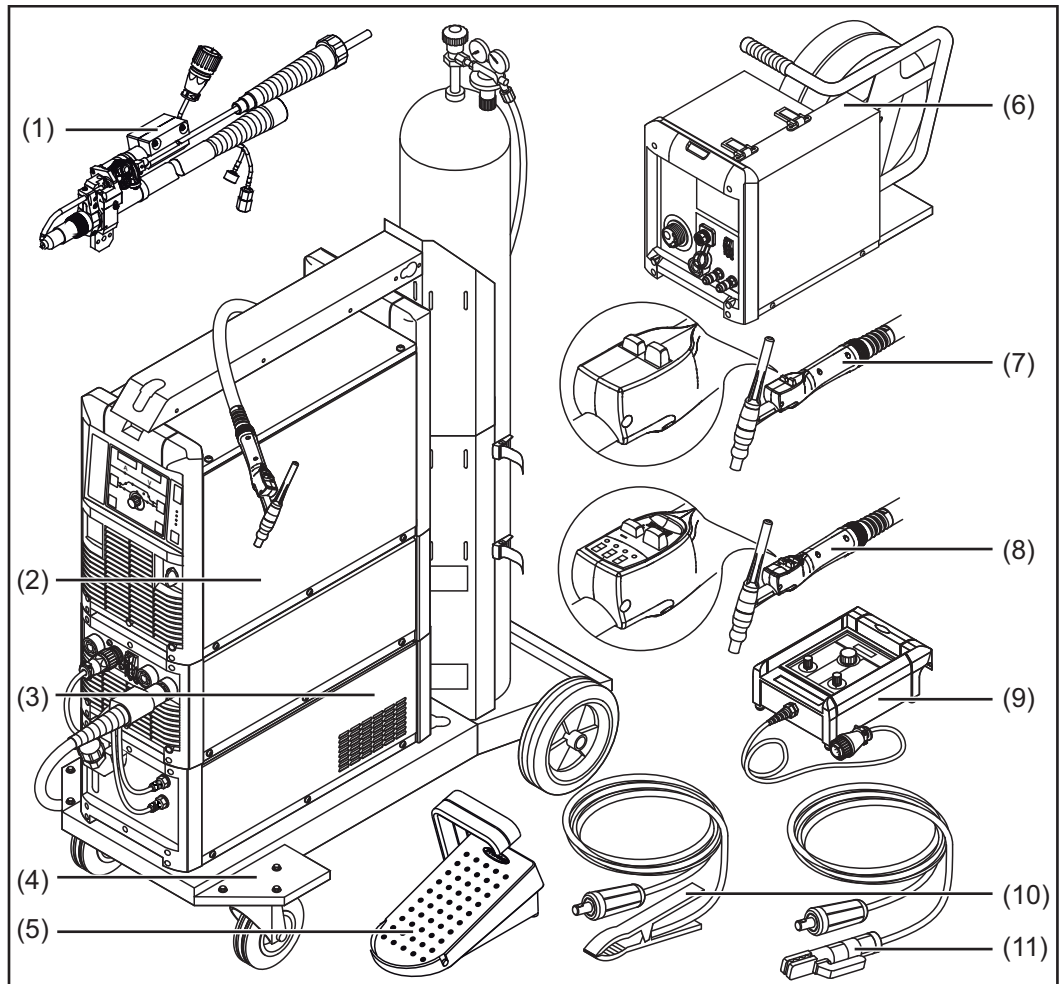

System add-ons and options

Item	Description
(1)	TIG robot welding torch Cold wire feeders with wire drive
(2)	Power sources
(3)	Cooling units
(4)	Trolley with gas cylinder holder
(5)	Pedal remote control unit
(6)	Cold wire-feed unit
(7)	TIG welding torch Standard / Up/Down
(8)	JobMaster TIG welding torch
(9)	Remote control units and robot accessories
(10)	Grounding (earthing) cable
(11)	Electrode cable

Control elements and connections

Description of the control panels

General

The key feature of the control panel is the logical way in which the control elements are arranged. All the main welding parameters needed for day-to-day working can easily be:

- selected using the buttons
- altered with the adjusting dial
- shown during welding on the digital display.

NOTE!

Due to software updates, you may find that your device has certain functions that are not described in these operating instructions or vice versa.

Individual illustrations may also differ slightly from the actual controls on your device, but these controls function in exactly the same way.

Safety



WARNING!

Danger from incorrect operation.

Possible serious injury and damage to property.

- ▶ Do not use the functions described here until you have read and completely understood these Operating Instructions.
 - ▶ Do not use the functions described here until you have fully read and understood all of the Operating Instructions for the system components, in particular the safety rules!
-

Overview

"Description of the control panels" is composed of the following sections:

- MagicWave control panel
- TransTig control panel
- Key combinations - special functions

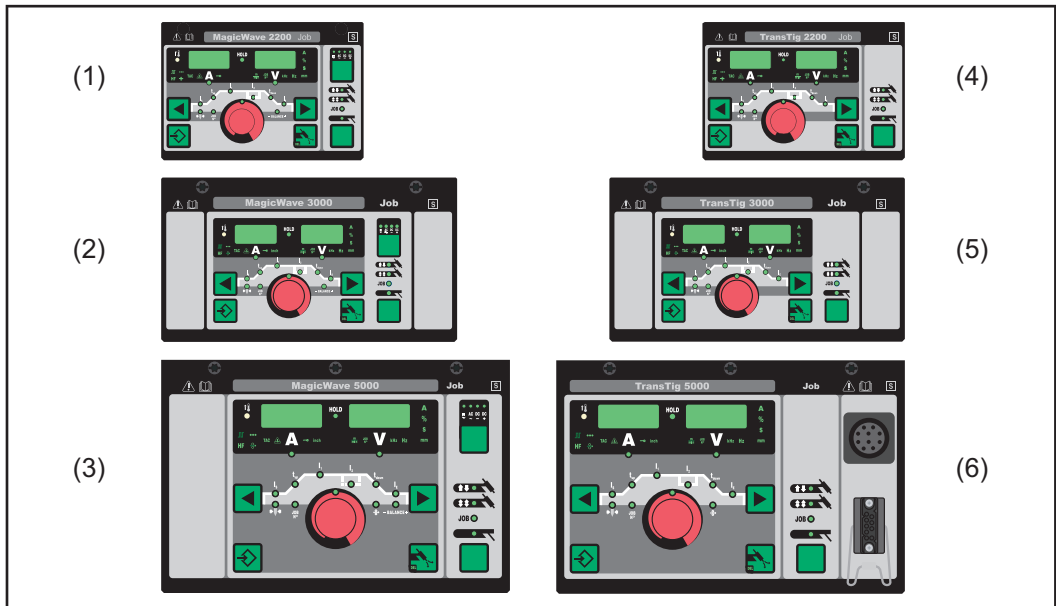

MagicWave control panels:

- (1) MW 1700 / 2200
- (2) MW 2500 / 3000
- (3) MW 4000 / 5000

TransTig control panels:

- (4) TT 800 / 2200
- (5) TT 2500 / 3000
- (6) TT 4000 / 5000





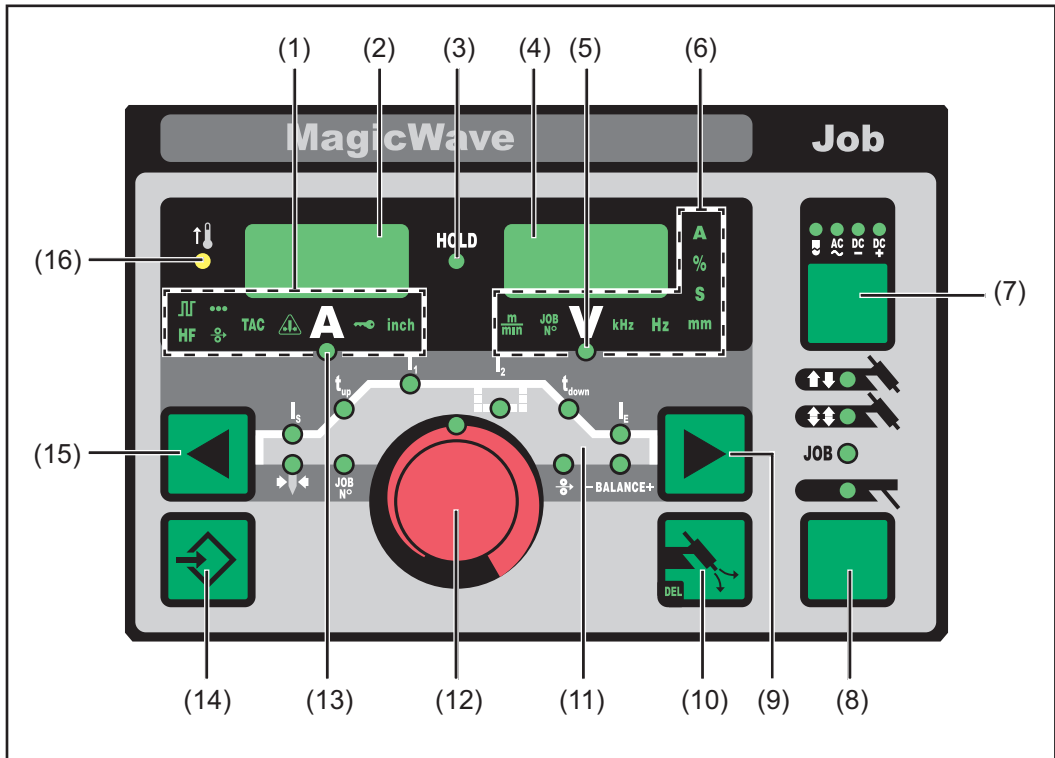



MagicWave control panel

MagicWave control panel



No. Function

(1) Special indicators

-  **Pulse indicator**
lights up when the F-P setup parameter has been set to a pulse frequency
-  **Spot welding indicator**
lights up when the SPT setup parameter has been set to a spot welding time
-  **Tacking indicator**
lights up when the tAC setup parameter has been set to a period of time
-  **Electrode overload indicator**
lights up if the tungsten electrode is overloaded
See section on TIG welding in Chapter "Welding mode" for more information on the electrode overload indicator.
-  **Keylock indicator**
lights up when the keylock is activated
-  **Inch indicator** (only for MagicWave 2500 / 3000 / 4000 / 5000)
lights up, when the setup parameter SEt is set to US
-  **HF (high frequency) ignition indicator**
lights up when the HFt setup parameter has been set to an interval for the high frequency pulses
-  **Cold wirefeeder indicator**
lights up when a cold wirefeeder is connected

(2) Left digital display

No. Function

(3) HOLD indicator

at the end of each welding operation, the actual values for the welding current and voltage are stored and the Hold indicator lights up.

The Hold indicator refers to the last value reached by the main current I_1 . As soon as any other welding parameter is selected, the Hold indicator goes off. The Hold values will continue to be available, however, if welding parameter I_1 is selected again.

The Hold indicator is cleared when:

- a new welding operation is started
- the welding current I_1 is set
- the mode is changed
- the welding process is changed

IMPORTANT! Hold values are not output if

- the main current phase was never reached,
or
- a pedal remote control was used.

(4) Right digital display

(5) Welding voltage indicator

lights up when parameter I_1 is selected. During welding the current actual value for the welding voltage is shown on the right-hand digital display.

Before welding, the following appears on the right digital display:

- 0.0 if a TIG welding mode is selected
- 50 V if an MMA welding mode is selected (after a delay of 3 seconds; 50 V is approximately the average value for the pulsed open circuit voltage)

(6) Unit indicators

**m/min indicator**

lights up when welding parameter Fd.1 or setup parameter Fd.2 has been selected

**Job N° indicator**

lights up in Job mode

**kHz indicator**

lights up when the F-P setup parameter is selected if the value entered for the pulse frequency ≥ 1000 Hz

**Hz indicator**

lights up when:

- the F-P setup parameter is selected if the value entered for the pulse frequency < 1000 Hz
- setup parameter ACF has been selected

**A indicator****% indicator**

lights up when the I_S , I_2 and I_E welding parameters and the dcY, I-G and HCU setup parameters have been selected

**s indicator**

lights up when the t_{up} and t_{down} welding parameters plus the following set-up parameters have been selected:

- GPr - tAC - dt2 - lto
- G-L - t-S - Hti - Arc
- G-H - t-E - Ct
- SPt - dt1 - HFt

No. Function
**mm indicator**

lights up when the Fdb setup parameter has been selected

(7) Process button

for selecting the welding process depending on the mode that has been chosen

2-step mode/4-step mode:automatic cap-shaping;
only available in conjunction with TIG AC welding process

TIG AC welding process



TIG DC- welding process

Job mode:

The welding process stored for the current job is displayed.

Manual metal arc welding mode:

MMA AC welding process



MMA DC- welding process



MMA DC+ welding process

When a welding process is selected, the LED on the relevant symbol lights up.

(8) Mode button

for selecting the mode



2-step mode



4-step mode



Job mode



MMA welding

When a mode is selected, the LED on the relevant symbol lights up.

(9) Right parameter selection button

for selecting welding parameters within the welding parameters overview (11)

When a welding parameter is selected, the LED on the relevant parameter symbol lights up.

(10) Gas-test buttonto set the required shielding gas flow rate on the pressure regulator
After pressing this button, shielding gas flows for 30 seconds. Press the button again to stop the gas flow prematurely.

No. Function

(11) Welding parameters overview

The welding parameters overview contains the most important welding parameters to be used when welding. The sequence of welding parameters follows a clothes-line structure. Use the left and right welding parameter selection buttons to navigate within the welding parameters overview.

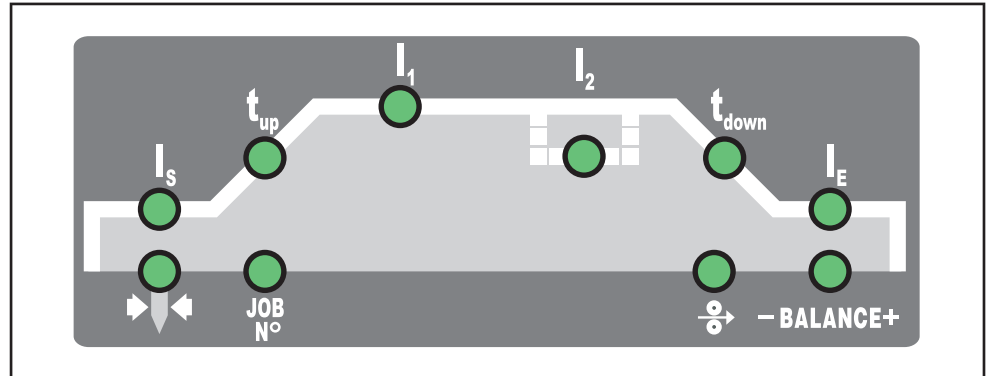

Welding parameters overview

The welding parameters overview contains the following welding parameters:

**Starting current I_s**

for TIG welding

The starting current I_s is saved separately for the "TIG AC welding" and "TIG DC- welding" modes.

**UpSlope t_{up}**

when TIG welding, the period over which the current is increased from the starting current I_s to the specified main current I_1

The UpSlope t_{up} is saved separately for 2-step and 4-step modes.

**Main current I_1 (welding current)**

- for TIG welding
- for MMA welding

**Reduced current I_2**

for TIG 4-step mode and TIG special 4-step mode

**DownSlope t_{down}**

when TIG welding, the period over which the current is decreased from the specified main current I_1 to the final current I_E

The DownSlope t_{down} is saved separately for 2-step and 4-step modes.

**Final current I_E**

for TIG welding

**Balance**

used to set the fusing power/cleaning action for TIG AC welding

**Wire speed (only for MagicWave 4000 / 5000)**

for setting the Fd.1 welding parameter if the cold wirefeeder option is available

No. Function
**Job N°**

In Job mode for retrieving welding parameter records stored under job numbers.

**Electrode diameter**

used in TIG welding to enter the diameter of the tungsten electrode

(12) Adjusting dial

for altering welding parameters. If the indicator on the adjusting dial lights up, then the selected welding parameter can be altered.

(13) Welding current indicator

for indicating the welding current for the welding parameters

- Starting current I_S
- Welding current I_1
- Reduced current I_2
- Final current I_E

Before welding commences, the left-hand digital display shows the set value. For I_S , I_2 and I_E , the right-hand digital display also shows the respective percentage of the welding current I_1 .

After welding begins, the welding parameter I_1 is automatically selected. The left-hand digital display shows the actual welding current value.

In the welding parameters overview (11), LEDs for the various parameters (I_S , t_{up} , etc.) light up to show the relevant position in the welding process.

(14) Store button

used to store jobs and access the Setup menu

(15) Left parameter selection button

for selecting welding parameters within the welding parameters overview (11)

When a welding parameter is selected, the LED on the relevant parameter symbol lights up.

(16) Overtemperature indicator

lights up if the power source overheats (e.g. because the duty cycle has been exceeded). See the "Troubleshooting" section for more information.

(17) Keylock switch (option for MW 2500 / 3000 / 4000 / 5000)

When the key is in the horizontal position, all parameters and functions are disabled with the exception of the currently selected parameter or function.

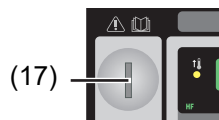

Keylock switch position

IMPORTANT! The functions available on the control panel of system components are restricted in the same way as those on the control panel of the power source.

TransTig control panel

TransTig control panel

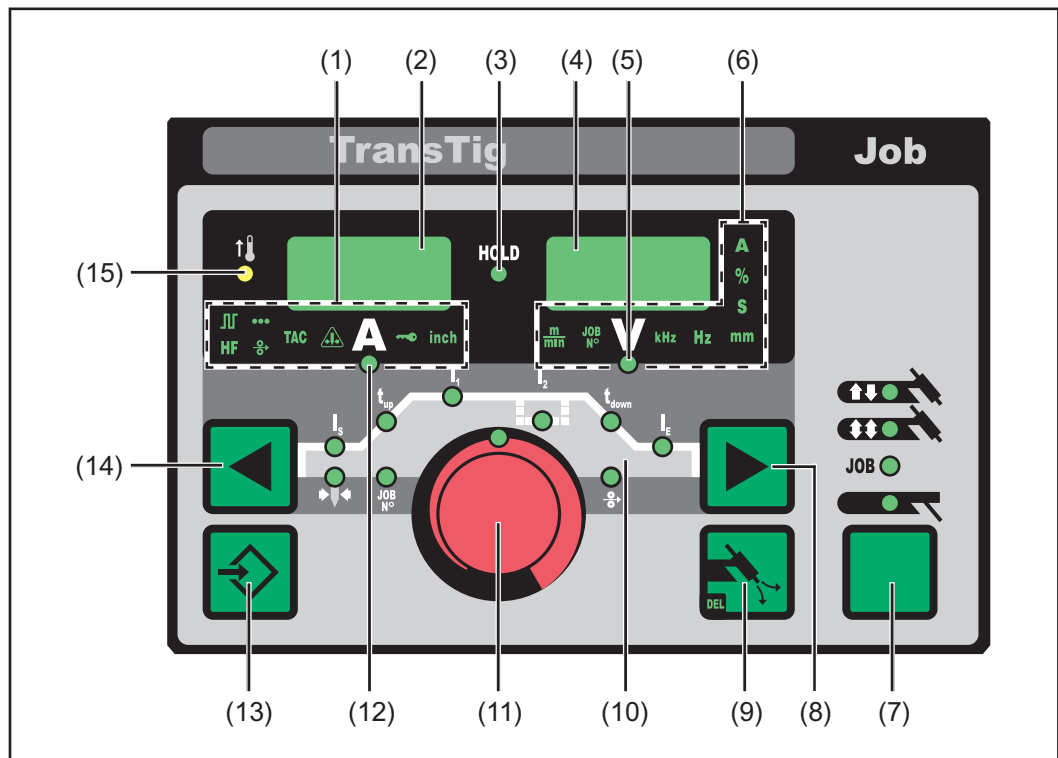

No. Function

(1) Special indicators



Pulse indicator

lights up when the F-P setup parameter has been set to a pulse frequency



Spot welding indicator

lights up when the SPT setup parameter has been set to a spot welding time



Tacking indicator

lights up when the tAC setup parameter has been set to a period of time



Electrode overload indicator

lights up if the tungsten electrode is overloaded

See section on TIG welding in Chapter "Welding mode" for more information on the electrode overload indicator.



Keylock indicator

lights up when the keylock is activated



Inch indicator (only for TransTig 2500 / 3000 / 4000 / 5000)

lights up, when the setup parameter SEt is set to US



HF (high frequency) ignition indicator

lights up when the HFt setup parameter has been set to an interval for the high frequency pulses



Cold wirefeeder indicator

lights up when a cold wirefeeder is connected

(2) Left digital display

No. Function

(3) HOLD indicator

at the end of each welding operation, the actual values for the welding current and voltage are stored and the Hold indicator lights up.

The Hold indicator refers to the last value reached by the main current I_1 . As soon as any other welding parameter is selected, the Hold indicator goes off. The Hold values will continue to be available, however, if welding parameter I_1 is selected again.

The Hold indicator is cleared when:

- a new welding operation is started
- the welding current I_1 is set
- the mode is changed
- the welding process is changed

IMPORTANT! Hold values are not output if

- the main current phase was never reached,
or
 - a pedal remote control was used.
-

(4) Right digital display**(5) Welding voltage indicator**

lights up when parameter I_1 is selected. During welding the current actual value for the welding voltage is shown on the right-hand digital display.

Before welding, the following appears on the right digital display:

- 0.0 if a TIG welding mode is selected
 - 50 V if an MMA welding mode is selected (after a delay of 3 seconds; 50 V is approximately the average value for the pulsed open circuit voltage)
-

(6) Unit indicators**m/min indicator**

lights up when welding parameter Fd.1 or setup parameter Fd.2 has been selected

**Job N° indicator**

lights up in Job mode

**kHz indicator**

lights up when the F-P setup parameter is selected if the value entered for the pulse frequency ≥ 1000 Hz

**Hz indicator**

lights up when:

- the F-P setup parameter is selected if the value entered for the pulse frequency < 1000 Hz
- setup parameter ACF has been selected

**A indicator****% indicator**

lights up when the I_S , I_2 and I_E welding parameters and the dcY, I-G and HCU setup parameters have been selected

**s indicator**

lights up when the t_{up} and t_{down} welding parameters plus the following set-up parameters have been selected:

- | | | | |
|-------|-------|-------|-------|
| - GPr | - tAC | - dt2 | - lto |
| - G-L | - t-S | - Hti | - Arc |
| - G-H | - t-E | - Ct | |
| - SPt | - dt1 | - HFt | |

No. Function



mm indicator

lights up when the Fdb setup parameter has been selected

(7) Mode button

for selecting the mode



2-step mode



4-step mode



Job mode



MMA welding

When a mode is selected, the LED on the relevant symbol lights up.

(8) Right parameter selection button

for selecting welding parameters within the welding parameters overview (10)

When a welding parameter is selected, the LED on the relevant parameter symbol lights up.

(9) Gas-test button

to set the required shielding gas flow rate on the pressure regulator

After pressing this button, shielding gas flows for 30 seconds. Press the button again to stop the gas flow prematurely.

(10) Welding parameters overview

The welding parameters overview contains the most important welding parameters to be used when welding. The sequence of welding parameters follows a clothes-line structure. Use the left and right welding parameter selection buttons to navigate within the welding parameters overview.

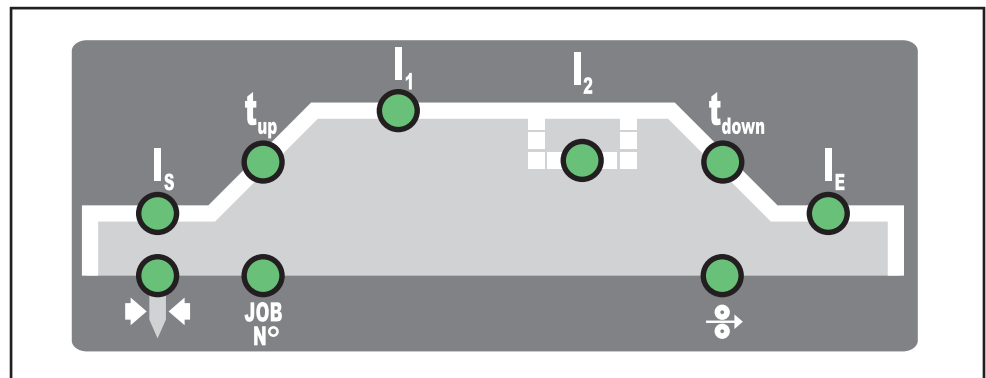

Welding parameters overview

The welding parameters overview contains the following welding parameters:



Starting current I_s

for TIG welding

The starting current I_s is saved separately for the "TIG AC welding" and "TIG DC- welding" modes.



UpSlope t_{up}

when TIG welding, the period over which the current is increased from the starting current I_s to the specified main current I_1

The UpSlope t_{up} is saved separately for 2-step and 4-step modes.



Main current I_1 (welding current)

- for TIG welding
- for MMA welding

No. Function
**Reduced current I_2**

for TIG 4-step mode and TIG special 4-step mode

**DownSlope t_{down}** when TIG welding, the period over which the current is decreased from the specified main current I_1 to the final current I_E The DownSlope t_{down} is saved separately for 2-step and 4-step modes.**Final current I_E**

for TIG welding

**Wire speed** (only for MagicWave 4000 / 5000)

for setting the Fd.1 welding parameter if the cold wirefeeder option is available

**Job N°**

In Job mode for retrieving welding parameter records stored under job numbers.

**Electrode diameter**

used in TIG welding to enter the diameter of the tungsten electrode

(11) Adjusting dial

for altering welding parameters. If the indicator on the adjusting dial lights up, then the selected welding parameter can be altered.

(12) Welding current indicator

for indicating the welding current for the welding parameters

- Starting current I_S
- Welding current I_1
- Reduced current I_2
- Final current I_E

Before welding commences, the left-hand digital display shows the set value. For I_S , I_2 and I_E , the right-hand digital display also shows the respective percentage of the welding current I_1 .

After welding begins, the welding parameter I_1 is automatically selected. The left-hand digital display shows the actual welding current value.

In the welding parameters overview (10), LEDs for the various parameters (I_S , t_{up} , etc.) light up to show the relevant position in the welding process.

(13) Store button

used to store jobs and access the Setup menu

(14) Left parameter selection button

for selecting welding parameters within the welding parameters overview (10)

When a welding parameter is selected, the LED on the relevant parameter symbol lights up.

(15) Overtemperature indicator

lights up if the power source overheats (e.g. because the duty cycle has been exceeded). See the "Troubleshooting" section for more information.

No. Function

(16) Keylock switch (option for TT 2500 / 3000 / 4000 / 5000)

When the key is in the horizontal position, all parameters and functions are disabled with the exception of the currently selected parameter or function.

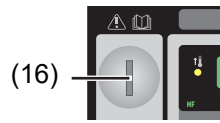

Keylock switch position

IMPORTANT! The functions available on the control panel of system components are restricted in the same way as those on the control panel of the power source.

Key combinations - special functions

General

The following functions can be called up by pressing buttons simultaneously or repeatedly on the MagicWave and TransTig control panels.

Keylock



To activate the keylock:
while pressing and holding the Store button, press the right parameter selection button



The lockout message "CLo|SEd" briefly appears on the display.
On the control panel, the special keylock indicator lights up

If you now press any of the buttons, the lockout message "CLo|SEd" will appear on the digital display. The adjusting dial can only be used to change the welding parameter that had been selected when the keylock was activated.



NOTE The keylock remains enabled even if the power source is switched off and then on again.



To deactivate the keylock:
while pressing and holding the Store button, press the right parameter selection button



The unlocking message "-OP|En-" appears briefly on the digital displays.
The special keylock indicator goes off.

Displaying the software version, operating time and coolant flow



Display software version:
while pressing and holding the Store button, press the left parameter selection button.
The software version appears on the digital displays.



Display operating time:
press the left parameter selection button again



The operating time records the actual arc burning time since starting for the first time.
For example: "654 | 32.1" = 65,432.1 hours = 65,432 hours | 6 mins

IMPORTANT! The operating time display is not suitable as a basis for calculating hiring fees, guarantee, etc.



Display coolant flow (only in conjunction with a cooling unit with the flow sensor option):
press the left parameter selection button again



The current coolant flow of the cooling unit is shown in l/min (CFL = Coolant Flow)
If the coolant flow is less than 0.7 l/min, the power source switches off after the end of the time specified in welding parameter C-t and the error message "no | H2O" is shown.



To exit, press the Store button.

Connections, switches and mechanical components

MagicWave 1700 / 2200 Job

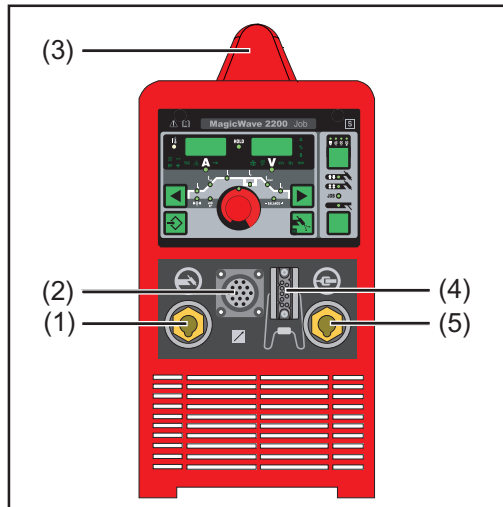

MagicWave 1700 / 2200 Job - front

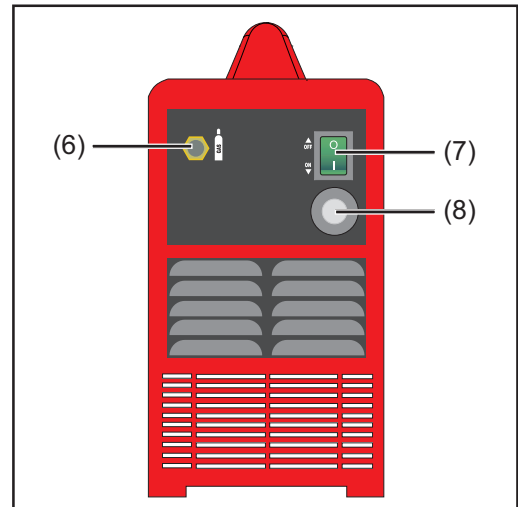

MagicWave 1700 / 2200 Job - rear

No.	Function
(1)	Welding torch connection for connecting: - the TIG welding torch - the electrode cable for manual metal arc welding
(2)	LocalNet connection standardised connection socket for system add-ons (e.g. remote control, JobMaster TIG welding torch, etc.)
(3)	Handle (only for MagicWave 2200) carrying strap for MagicWave 1700
(4)	Torch control connection - for connecting the control plug of a conventional welding torch - input for the collision protection signal when a robot interface or field bus coupler is connected
(5)	Grounding (earthing) cable connection for connecting the grounding (earthing) cable
(6)	Shielding gas connection
(7)	Mains switch for switching the power source on and off
(8)	Mains cable with strain relief device

**MagicWave
2500 / 3000 Job**

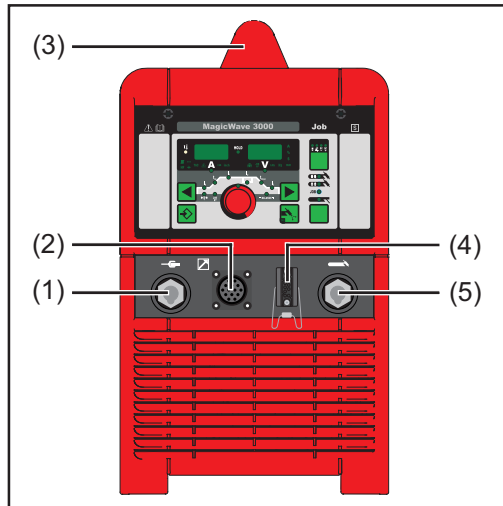

MagicWave 2500 / 3000 Job - front

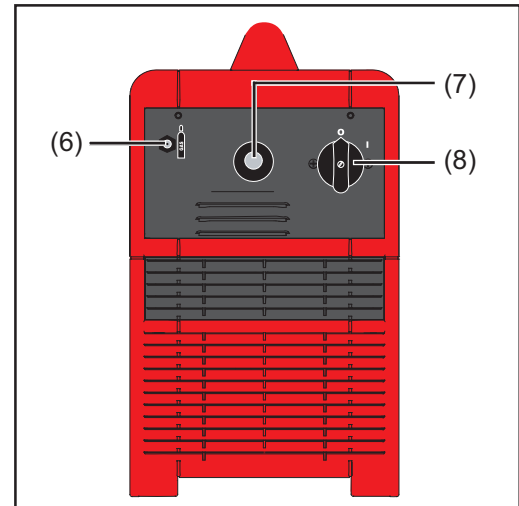

MagicWave 2500 / 3000 Job - rear

No. Function

- | | |
|------------|---|
| (1) | Grounding (earthing) cable connection
for connecting the grounding (earthing) cable |
| (2) | LocalNet connection
standardised connection socket for system add-ons (e.g. remote control, JobMaster TIG welding torch, etc.) |
| (3) | Handle |
| (4) | Torch control connection <ul style="list-style-type: none"> - for connecting the control plug of a conventional welding torch - input for the collision protection signal when a robot interface or field bus coupler is connected |
| (5) | Welding torch connection
for connecting: <ul style="list-style-type: none"> - the TIG welding torch - the electrode cable for manual metal arc welding |
| (6) | Shielding gas connection |
| (7) | Mains cable with strain relief device |
| (8) | Mains switch
for switching the power source on and off |

**MagicWave
4000 / 5000 Job**

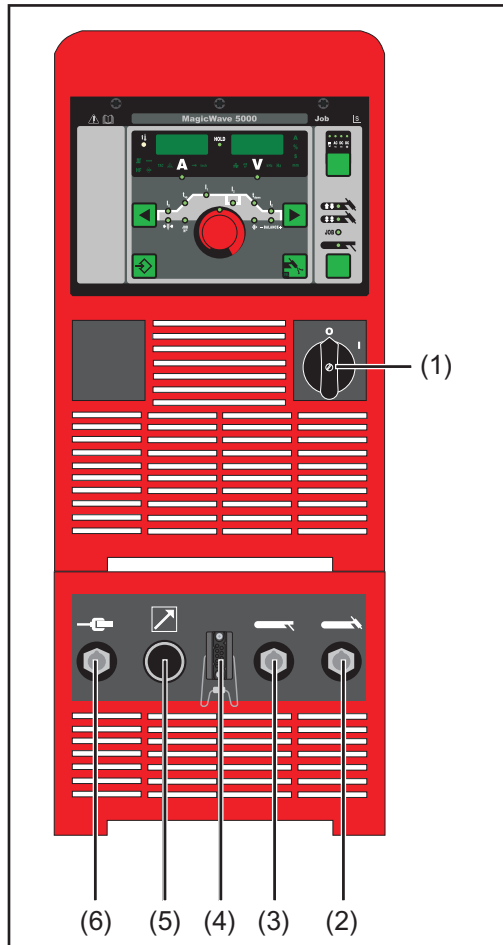

MagicWave 4000 / 5000 Job - front

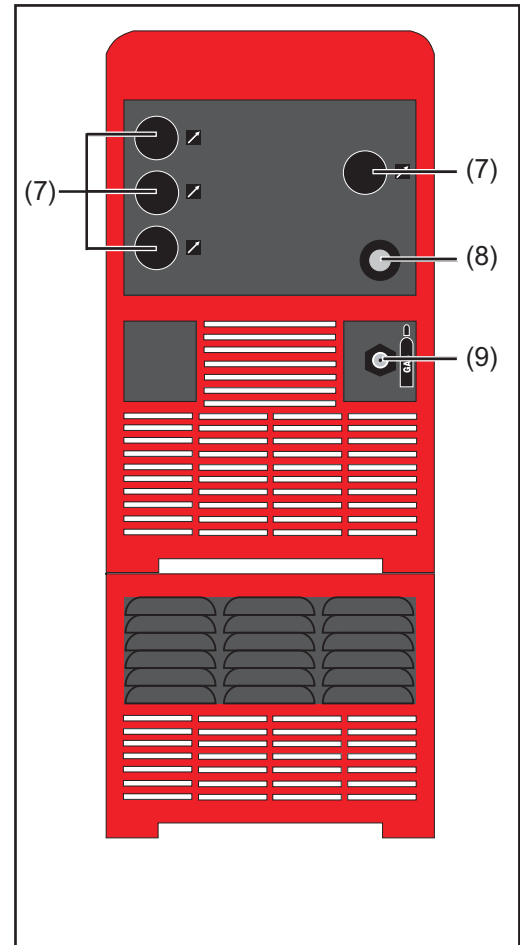

MagicWave 4000 / 5000 Job - rear

No. Function

- | | |
|--|---|
| (1) Mains switch | for switching the power source on and off |
| (2) Welding torch connection | for connecting the TIG welding torch |
| (3) Electrode holder connection | for connecting the electrode cable for manual metal arc welding |
| (4) Torch control connection | <ul style="list-style-type: none"> - for connecting the control plug of a conventional welding torch - input for the collision protection signal when a robot interface or field bus coupler is connected |
| (5) LocalNet connection | standardised connection socket for system add-ons (e.g. remote control, JobMaster TIG welding torch, etc.) |
| (6) Grounding (earthing) cable connection | for connecting the grounding (earthing) cable |
| (7) Blanking cover | reserved for LocalNet connection |
| (8) Mains cable with strain relief device | |
| (9) Shielding gas connection | |

**TransTig
800 / 2200 Job**

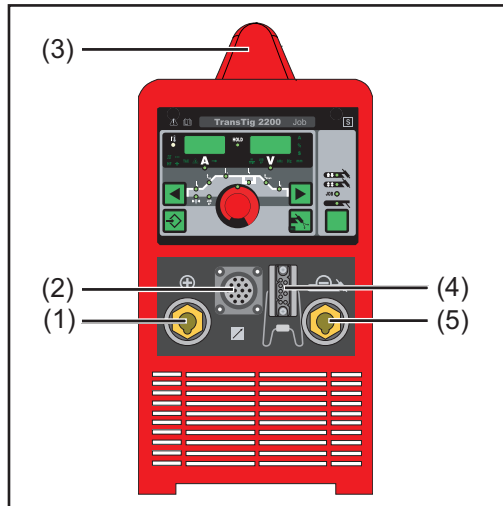

TransTig 800 / 2200 Job - front

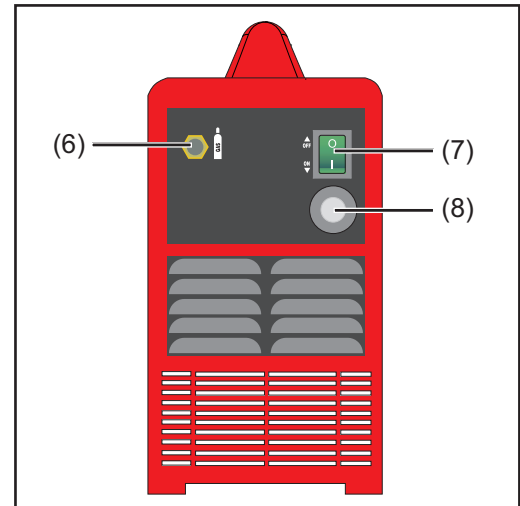

TransTig 800 / 2200 Job - rear

No. Function

- | | |
|-----|---|
| (1) | <p>(+) current socket with bayonet latch
for connecting</p> <ul style="list-style-type: none"> - the grounding (earthing) cable when TIG welding - the electrode cable or grounding (earthing) cable during MMA welding (depending on the type of electrode) |
| (2) | <p>LocalNet connection
standardised connection socket for system add-ons (e.g. remote control, JobMaster TIG welding torch, etc.)</p> |
| (3) | <p>Handle (only for TransTig 2200)
carrying strap for TransTig 800</p> |
| (4) | <p>Torch control connection</p> <ul style="list-style-type: none"> - for connecting the control plug of a conventional welding torch - input for the collision protection signal when a robot interface or field bus coupler is connected |
| (5) | <p>(-) current socket with bayonet latch
for connecting</p> <ul style="list-style-type: none"> - the TIG welding torch - the electrode cable or grounding (earthing) cable during MMA welding (depending on electrode type) |
| (6) | <p>Shielding gas connection</p> |
| (7) | <p>Mains switch
for switching the power source on and off</p> |
| (8) | <p>Mains cable with strain relief device</p> |

**TransTig
2500 / 3000 Job**

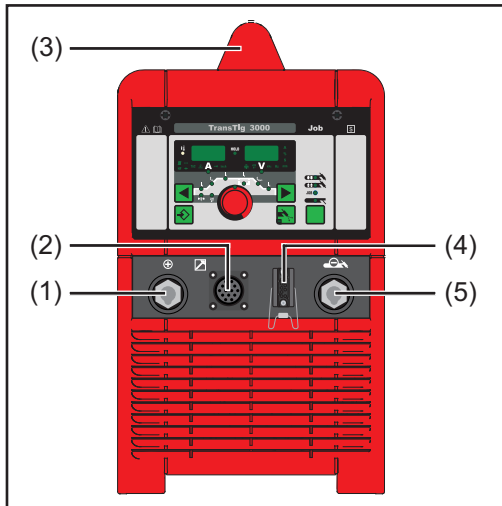

TransTig 2500 / 3000 Job - front

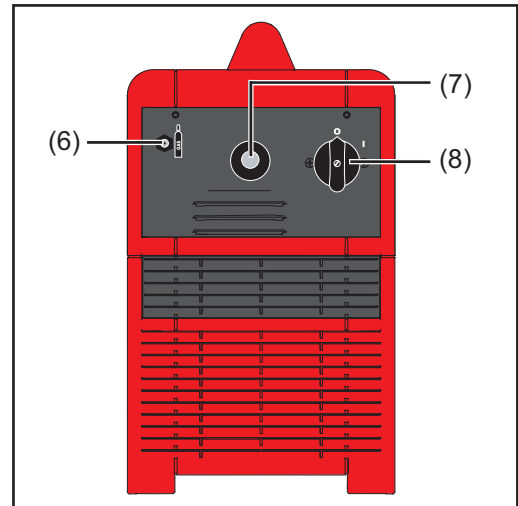

TransTig 2500 / 3000 Job - rear

No. Function

- (1) (+) current socket with bayonet latch**
for connecting
- the grounding (earthing) cable when TIG welding
 - the electrode cable or grounding (earthing) cable during MMA welding (depending on electrode type)
-
- (2) LocalNet connection**
standardised connection socket for system add-ons (e.g. remote control, JobMaster TIG welding torch, etc.)
-
- (3) Handle**
-
- (4) Torch control connection**
- for connecting the control plug of a conventional welding torch
 - input for the collision protection signal when a robot interface or field bus coupler is connected
-
- (5) (-) current socket with bayonet latch**
for connecting
- the TIG welding torch
 - the electrode cable or grounding (earthing) cable during MMA welding (depending on the type of electrode)
-
- (6) Shielding gas connection**
-
- (7) Mains cable with strain relief device**
-
- (8) Mains switch**
for switching the power source on and off
-

**TransTig
4000 / 5000 Job**

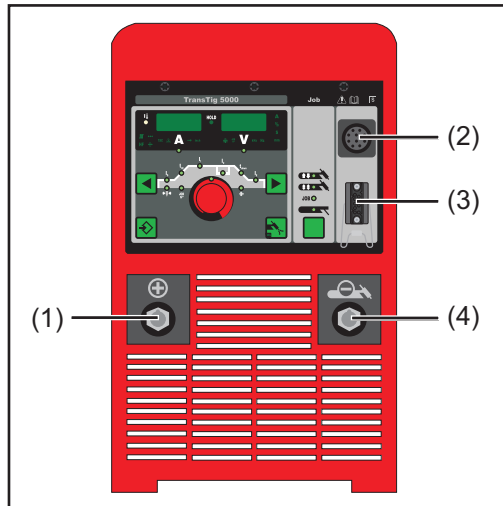

TransTig 4000 / 5000 Job - front

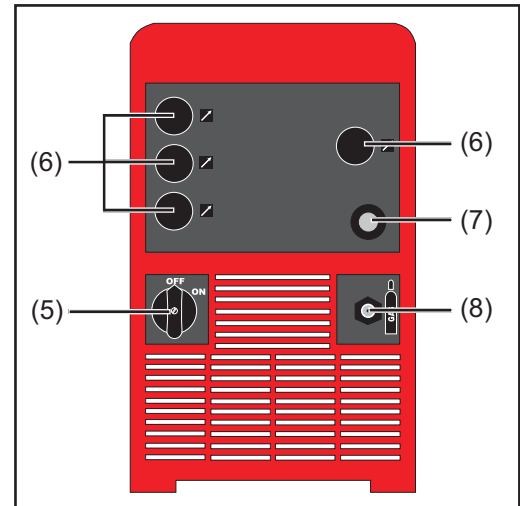

TransTig 4000 / 5000 Job - rear

No. Function

- | | |
|-----|---|
| (1) | <p>(+) current socket with bayonet latch
for connecting</p> <ul style="list-style-type: none"> - the grounding (earthing) cable when TIG welding - the electrode cable or grounding (earthing) cable during MMA welding (depending on the type of electrode) |
| (2) | <p>LocalNet connection
standardised connection socket for system add-ons (e.g. remote control, JobMaster TIG welding torch, etc.)</p> |
| (3) | <p>Torch control connection</p> <ul style="list-style-type: none"> - for connecting the control plug of a conventional welding torch - input for the collision protection signal when a robot interface or field bus coupler is connected |
| (4) | <p>(-) current socket with bayonet latch
for connecting</p> <ul style="list-style-type: none"> - the TIG welding torch - the electrode cable or grounding (earthing) cable during MMA welding (depending on the type of electrode) |
| (5) | <p>Mains switch
for switching the power source on and off
OFF = - O -
ON = - I -</p> |
| (6) | <p>Blanking cover
reserved for LocalNet connection</p> |
| (7) | <p>Mains cable with strain relief device</p> |
| (8) | <p>Shielding gas connection</p> |

Installation and commissioning

Minimum equipment needed for welding task

General

Depending on which welding process you intend to use, a certain minimum equipment level will be needed in order to work with the power source. The welding processes and the minimum equipment levels required for the welding task are then described.

TIG AC welding

- MagicWave power source
 - Grounding (earthing) cable
 - TIG welding torch with rocker switch
 - Gas connection (shielding gas supply), with pressure regulator
 - Filler metals (as required by the application)
-

TIG DC welding

- Power source
 - Grounding (earthing) cable
 - TIG welding torch with rocker switch
 - Gas connection (shielding gas supply)
 - Filler metals (as required by the application)
-

Automated TIG welding

- Power source
 - Robot interface or field bus connection
 - Grounding (earthing) cable
 - TIG machine welding torch or TIG robot welding torch
(a cooling unit is also required with water-cooled machine or robot welding torches)
 - Gas connection (shielding gas supply)
 - Cold wire-feed unit and filler metals (as required by the application)
-

MMA welding

- Power source
- Grounding (earthing) cable
- Electrode holder
- Rod electrodes (as required by the application)

Before installation and commissioning

Safety



WARNING!

Danger due to incorrect operation and incorrectly performed work.

This can result in severe personal injury and damage to property.

- ▶ All the work and functions described in this document must only be carried out and used by trained and qualified personnel.
 - ▶ Fully read and understand this document.
 - ▶ Fully read and understand all the Operating Instructions for the system components, especially the safety rules.
-

Utilisation for intended purpose

The power source is intended exclusively for TIG and MMA welding.

Utilisation for any other purpose, or in any other manner, shall be deemed to be not in accordance with the intended purpose.

The manufacturer shall not be liable for any damage resulting from such improper use.

Proper use also includes:

- following all the information in the operating instructions
 - carrying out all the specified inspection and servicing work
-

Setup regulations

The device is tested to IP 23 protection, meaning:

- Protection against penetration by solid foreign bodies with diameters > 12.5 mm (0.49 in.)
- Protection against spraywater at any angle up to 60° to the vertical

The device can be set up and operated outdoors in accordance with degree of protection IP 23.

Avoid direct wetting (e.g. from rain).



WARNING!

Toppling or falling devices can cause life-threatening injuries.

- ▶ Place devices on a solid, level surface so that they remain stable.
-

The venting duct is a very important safety device. When choosing the installation location, ensure that the cooling air can enter and exit unhindered through the air ducts on the front and back of the device. Electroconductive metallic dust (e.g. from grinding work) must not be allowed to get sucked into the device.

Mains connection

The devices are designed for the mains voltage specified on the rating plate. If your version of the appliance does not come with mains cables and plugs ready-fitted, these must be fitted in accordance with national regulations and standards. For details of fuse protection of the mains lead, please see the technical data.



CAUTION!

An inadequately dimensioned electrical installation can cause serious damage.

- ▶ The mains lead and its fuse must be dimensioned to suit the local power supply. The technical data shown on the rating plate applies.

Generator-powered operation (MW 1700 / 2200, TT 800 / 2200)

The MW 1700 / 2200 and TT 800 / 2200 power sources are generator-compatible, provided that the maximum apparent power delivered by the generator is at least 10 kVA.

IMPORTANT! The voltage delivered by the generator must never exceed the upper or lower limits of the mains voltage tolerance range. Details of the mains voltage tolerance can be found in the "Technical data" section.

Connecting up the mains cable on US power sources

General

The US power sources are supplied without a mains cable. A mains cable appropriate for the connection voltage must be fitted prior to commissioning.
A strain-relief device for a cable cross-section AWG 10 is installed on the power source. Strain-relief devices for larger cable cross-sections must be designed accordingly.

Stipulated mains cables and strain-relief devices

Power source	Mains voltage	Cable cross-section
TT 4000/5000 MV Job, MW 4000/5000 MV	3 x 380 - 460 V	AWG 10
Job	3 x 200 - 240 V	AWG 6

AWG ... **A**merican **W**ire **G**auge

Safety



WARNING!

Work that is carried out incorrectly can cause serious injury and damage.

- ▶ The following activities must only be carried out by trained and qualified personnel.
- ▶ Pay particular attention to the "Safety rules" sections in the power source and system component operating instructions.

Connecting the mains cable

- 1 Remove the left side panel of the power source
- 2 Strip about 100 mm (4 in.) of insulation from the end of the mains cable

NOTE!

The ground conductor (green, or green with yellow stripes) should be approx. 10 - 15 mm (0.4 - 0.6 in.) longer than the phase conductors.

- 3 Fit ferrules to phase conductors and the ground conductor of the mains cable; crimp ferrules with pliers



CAUTION!

Risk of short circuits!

If ferrules are not used, there is a risk of short circuits between the phase conductors or between phase conductors and the ground conductor.

- ▶ Fit ferrules to all phase conductors and the ground conductor of the stripped mains cable.

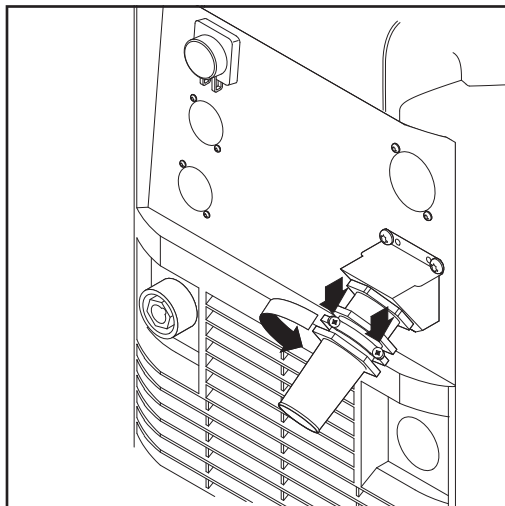

- 4** Undo the screws (2 x) and clamping nut (size 30) on the strain-relief device

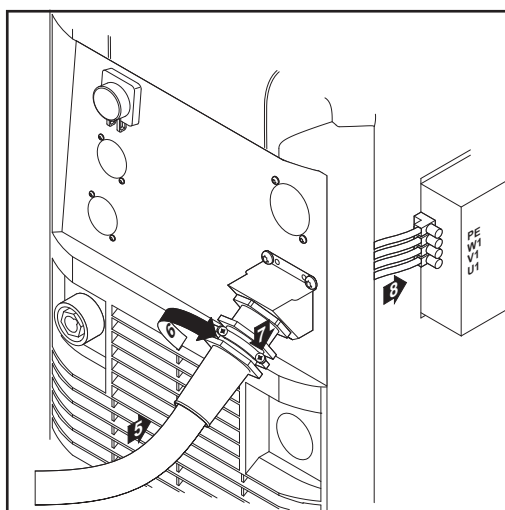

- 5** Insert the mains cable into the strain-relief device

NOTE!

Push the mains cable in far enough to make it possible to connect the ground conductor and the phase conductors to the block terminal properly.

- 6** Tighten the clamping nut (size 30 mm)
- 7** Tighten the screws (2 x)
- 8** Connect the mains cable to the block terminal correctly:
- Ground conductor (green, or green with yellow stripes) to the PE connection
 - Phase conductors to connections L1 - L3
- 9** Re-fit the left side panel of the power source

Replacing the strain-relief device

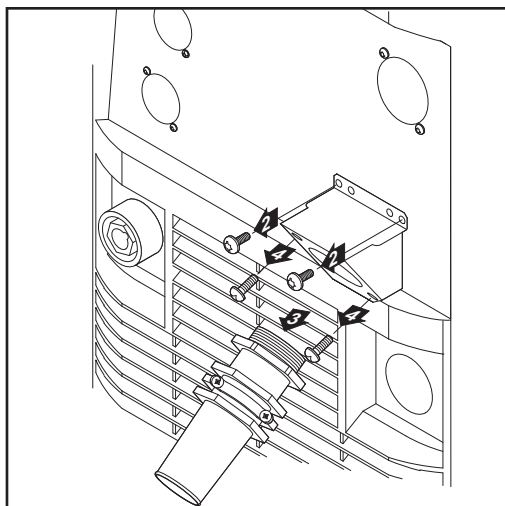

- 1** Remove the left side panel of the power source
- 2** Remove the screws (2 x) from the existing strain-relief device
- 3** Pull the existing strain-relief device forwards to detach it
- 4** Remove the screws for the adapter plate, and remove the adapter plate

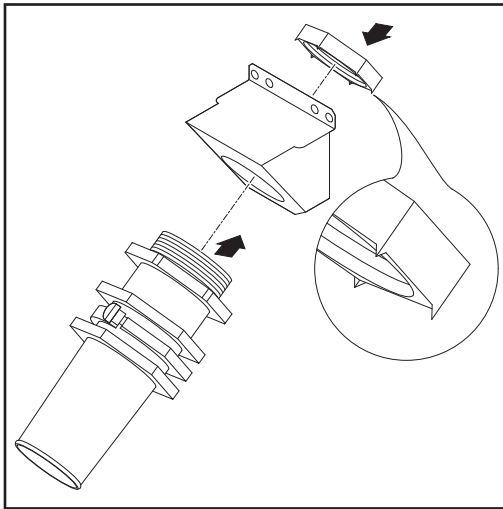

- 5 Insert the hexagon nut (size 50 mm) into the holding plate

NOTE!

To ensure a reliable earth connection to the housing of the power source, the points on the hexagon nut must be facing the holding plate.

- 6 Screw the front of the large strain-relief device into the hexagon nut (size 50 mm). The hexagon nut (size 50 mm) now bites into the holding plate.

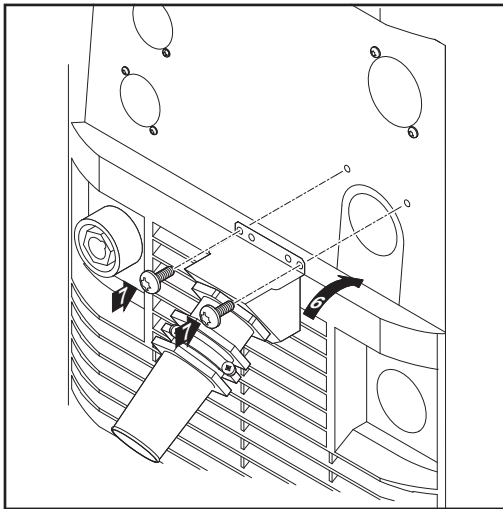

- 7 Slot the large strain-relief device into the housing and fasten it with 2 screws
- 8 Connect the mains cable
- 9 Re-fit the left side panel of the power source

Safety



WARNING!

An electric shock can be fatal.

If the device is plugged into the mains during installation, there is a high risk of very serious injury and damage.

- ▶ Only carry out work on the device if the mains switch is in the "O" position.
- ▶ Only carry out work on the charger when it has been disconnected from the mains supply.

Remarks on the cooling unit

We recommend using a cooling unit for the following applications and situations:

- JobMaster TIG welding torch
- Robot welding
- Hosepacks over 5 m long
- TIG AC welding
- In general, where welding is performed in higher power ranges

The cooling unit is powered from the power source. The cooling unit is ready for operation when the mains switch of the power source is in the "I" position.

More information on the cooling unit can be found in the operating instructions for the cooling unit.

General

This section describes how to commission the power source:

- for the main TIG welding application
- with reference to a standard configuration for a TIG welding device.

The standard configuration consists of the following system components:

- power source
- cooling unit
- TIG manual welding torch
- pressure regulator
- gas cylinder
- gas cylinder holder
- trolley

The steps set out below provide an overview of how to commission the power source. For detailed information about the individual steps, please refer to the operating instructions for the system components.

Connecting the gas cylinder



WARNING!

If gas cylinders topple over, there is a risk of very serious injury and damage.

- ▶ Place gas cylinders on a solid, level surface in such a way that they remain stable
- ▶ Secure gas cylinders to prevent them from toppling over: fix the safety strap at the same height as the top part of the cylinder
- ▶ Never fix the safety strap around the neck of the cylinder

Follow the gas cylinder manufacturer's safety instructions.

- 1 Secure the gas cylinder
- 2 Take the protective cap off the gas cylinder
- 3 Briefly open the gas cylinder valve to remove any dust or dirt
- 4 Check the seal on the pressure regulator
- 5 Screw the pressure regulator onto the gas cylinder and tighten it

When using a TIG welding torch with an integral gas connector:

- 6 Use the gas hose to connect the pressure regulator to the shielding gas connection on the rear of the power source
- 7 Tighten the union nut on the gas hose

When using a TIG welding torch with no integral gas connector:

- 6 Connect the TIG welding torch gas hose to the pressure regulator

Establishing a ground (earth) connection to the workpiece

- 1 Move the mains switch to the O position
- 2 Plug the grounding (earthing) cable in and latch it
 - for MagicWave: in the grounding (earthing) cable connection
 - for TransTig: in the (+) current socket
- 3 Use the other end of the grounding (earthing) cable to establish a connection to the workpiece

Connecting the welding torch

 **CAUTION!**

Risk of damage from high frequencies.

- ▶ Do not use the JobMaster TIG welding torch with a LocalNet distributor.

-
- 1 Move the mains switch to the "O" position
 - 2 Plug in the TIG welding torch welding power-lead and latch it by turning it clockwise:
 - for MagicWave: in the welding torch connection
 - for TransTig: in the (-) current socket
 - 3 Plug the welding torch control plug into the torch control connection and latch it
or
connect the control line of the JobMaster TIG welding torch to the LocalNet connection

NOTE!

Do not use pure tungsten electrodes (colour-coded green) on TransTig power sources.

-
- 4 Set up the welding torch in accordance with the welding torch Operating Instructions
 - 5 Only when using a water-cooled torch and cooling unit:
Plug in the welding torch water connections to the water flow (black) and return (red) connections on the cooling unit.

Welding

TIG modes

Safety

⚠ WARNING!

Danger from incorrect operation.

Possible serious injury and damage to property.

- ▶ Do not use the functions described here until you have read and completely understood these Operating Instructions.
- ▶ Do not use the functions described here until you have fully read and understood all of the Operating Instructions for the system components, in particular the safety rules!

See the "The Setup menu" section for information on the settings, setting range and units of measurement of the available welding parameters.

Symbols and their explanations

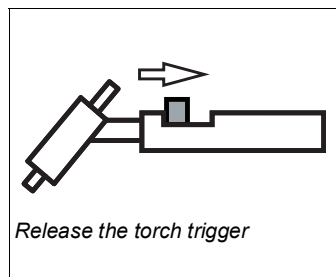
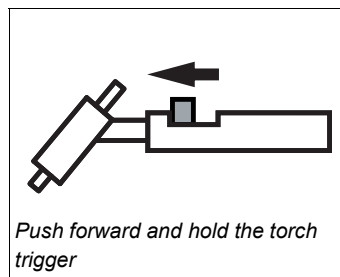
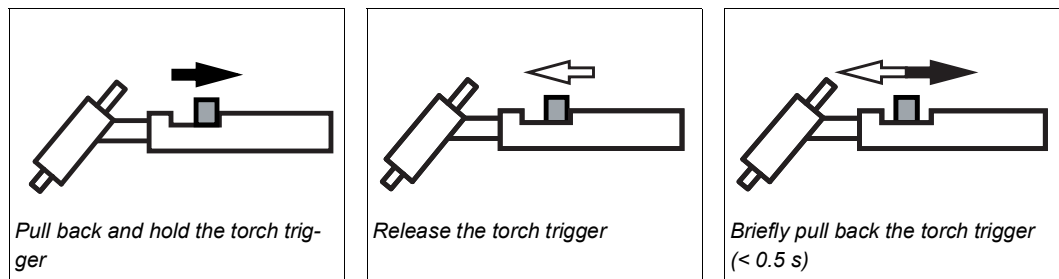

GPr Gas pre-flow time
I_s Starting-current phase: the temperature is raised gently at low welding current, so that the filler metal can be positioned correctly
t_s Starting current time
t_{up} Upslope phase: the starting current is continuously increased until it reaches the main current (welding current) I ₁

SPt Spot welding time
I_E Final current phase: to prevent any local overheating of the base material due to heat build-up towards the end of welding. This eliminates any risk of weld seam drop-through.
t_E Final current time
t_{down} Downslope phase: the welding current is continuously lowered until it reaches the end-crater current.

I₁
Main current phase (welding-current phase): uniform thermal input into the base material, whose temperature is raised by the advancing heat

G-H
Gas post-flow time at maximum welding current

I₂
Reduced current phase: intermediate lowering of the welding current in order to prevent any local overheating of the base material

G-L
Gas post-flow time at minimum welding current

2-step mode

- Welding: Pull back and hold the torch trigger
- End of welding: Release the torch trigger

NOTE!

To work in 2-step mode after it has been selected, the SPt setup parameter must be set to "OFF" and the spot welding indicator on the control panel must not light up.

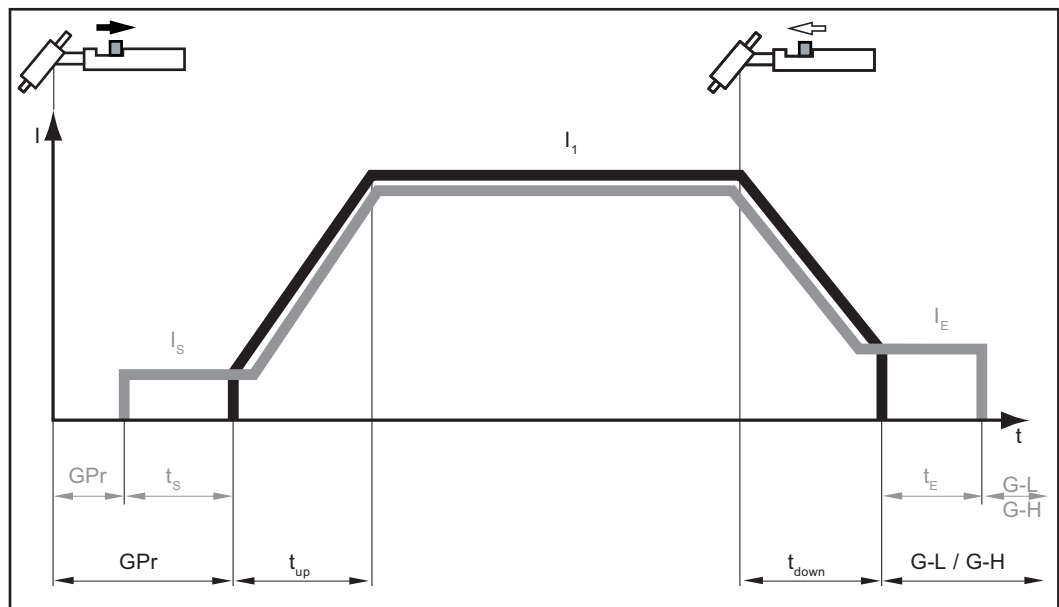

2-step mode

—... Manual application

—... Automatic application

Spot welding

If a value has been set for the SPt set-up parameter, 2-step mode will have the spot welding mode function. The special spot welding indicator on the control panel will light up.

- Welding: briefly pull back the torch trigger
The welding time corresponds to the value set for the SPt set-up parameter.
- to end the welding process prematurely: pull the torch trigger back again

When using a pedal remote control, the spot welding time starts when the pedal remote control is operated. The power cannot be controlled using the pedal remote control.

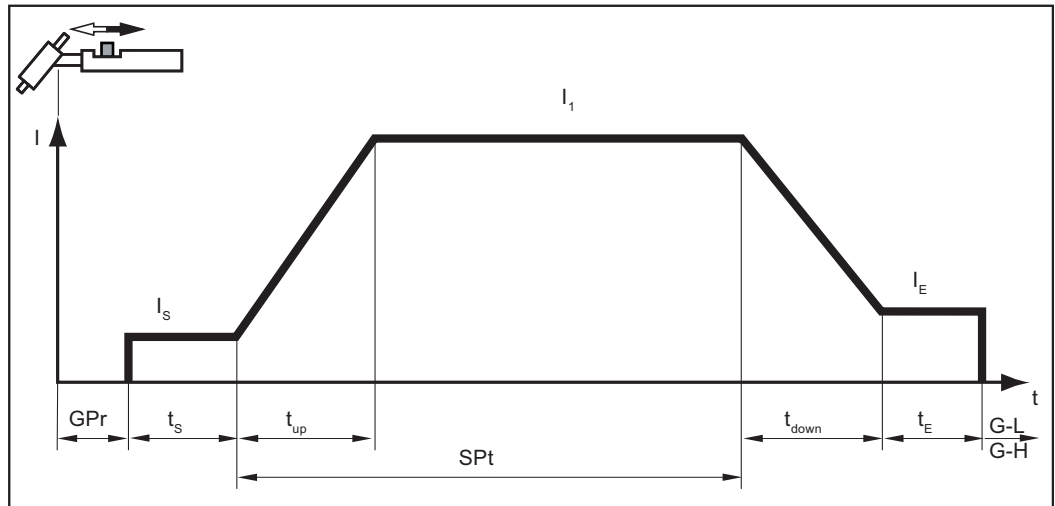

Spot welding

4-step mode

- Start of welding with starting current I_S : Pull back and hold the torch trigger
- Welding with main current I_1 : Release the torch trigger
- Lowering to final current I_E : Pull back and hold the torch trigger
- End of welding: Release the torch trigger

NOTE!

For 4-step mode, the special 4-step (SFS) setup parameter must be set to "OFF".

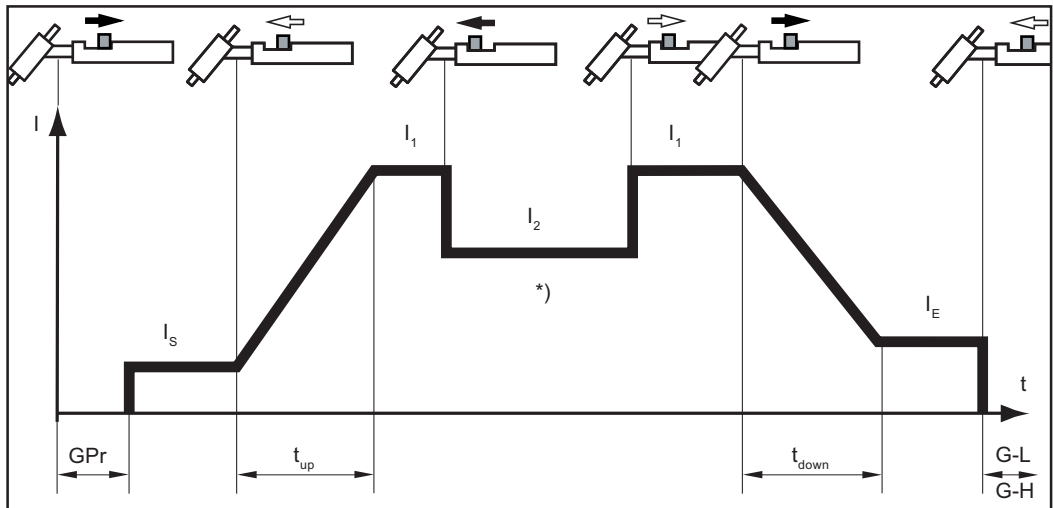

4-step mode

*) Intermediate lowering

Intermediate lowering during the main current phase reduces the welding current to the specified reduced current I_2 .

- To activate intermediate lowering, push forward and hold the torch trigger
- To revert to the main current, release the torch trigger

Special 4-step mode: variant 1

Variant 1 of special 4-step mode is activated, when the special 4-step (SFS) set-up parameter-is set to "1".
Briefly pull back the torch trigger to start intermediate lowering to the specified reduced current I_2 . Briefly pull back the torch trigger a second time, to restore the main current I_1 .

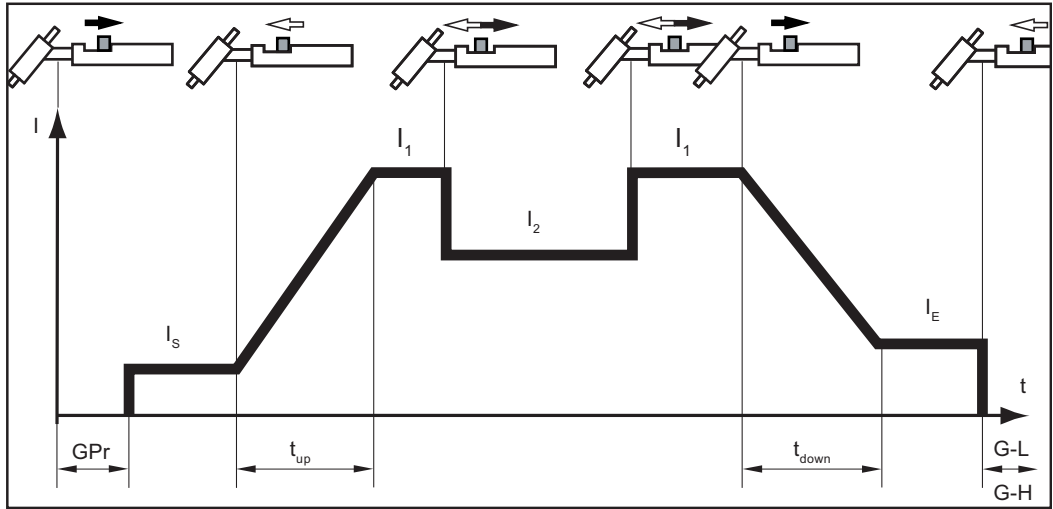

Special 4-step mode: Variant 1

Special 4-step mode: variant 2

Variant 2 of the special 4-step mode is activated when the special 4-step SFS set-up parameter -is set to "2".
Intermediate lowering takes place in variant 2 on the basis of the selected slope values - downslope t_{down} and upslope t_{up} :

- Push forward and hold the torch trigger: the welding current continuously drops at the set downslope value until it reaches the specified reduced current I_2 . It remains at the reduced current value I_2 until the torch trigger is released.
- When the torch trigger is released: the welding current rises at the specified upslope value until it reaches the main current value I_1 .

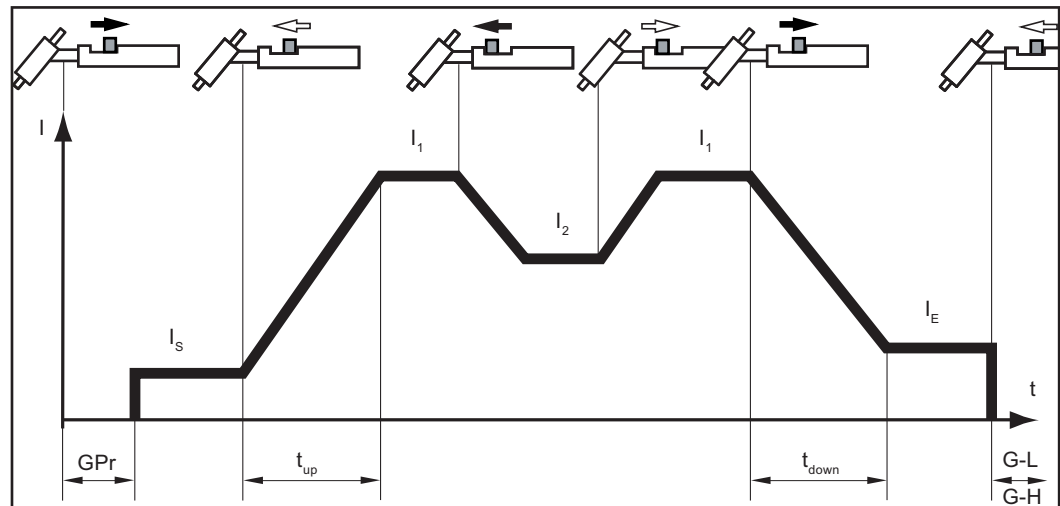

Special 4-step mode: Variant 2

**Special 4-step mode:
variant 3**

Variant 3 of special 4-step mode is activated when the special 4-step mode (SFS) set-up parameter -is set to "3".

In variant 3, push forward and hold the torch trigger to start intermediate lowering. Release the torch trigger to resume the main current I_1 .

When the torch trigger is pulled back, welding ends immediately without downslope and final current.

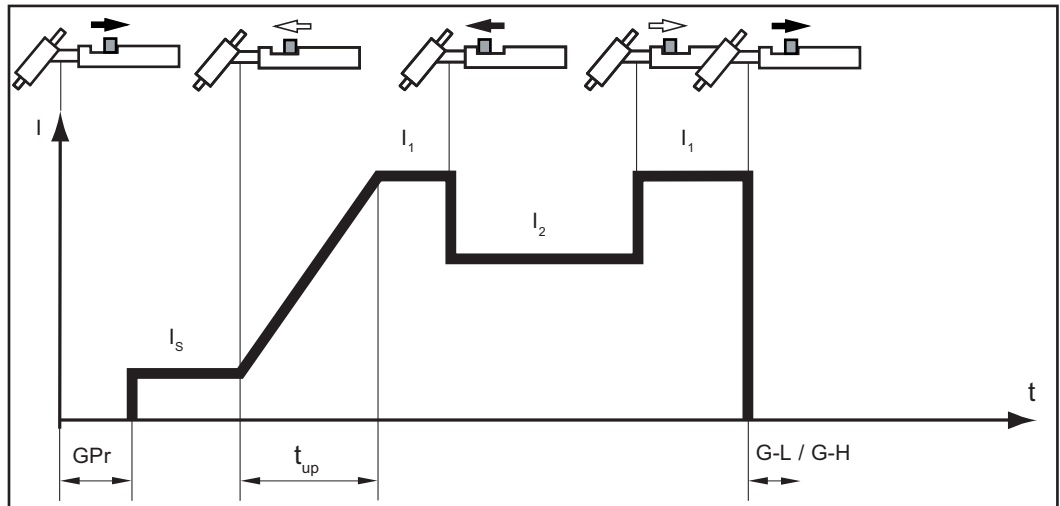

Special 4-step mode: Variant 3

**Special 4-step mode:
variant 4**

Variant 4 of the special 4-step mode is activated when the SFS set-up parameter is set to "4".

- Welding start-up and welding: briefly pull back and release the torch trigger - the welding current will rise at the specified upslope value from the starting current I_s until it reaches the main current value I_1 .
- Push forward and hold the torch trigger for intermediate lowering
- Release the torch trigger to resume the main current I_1
- End of welding: briefly pull back and release the torch trigger

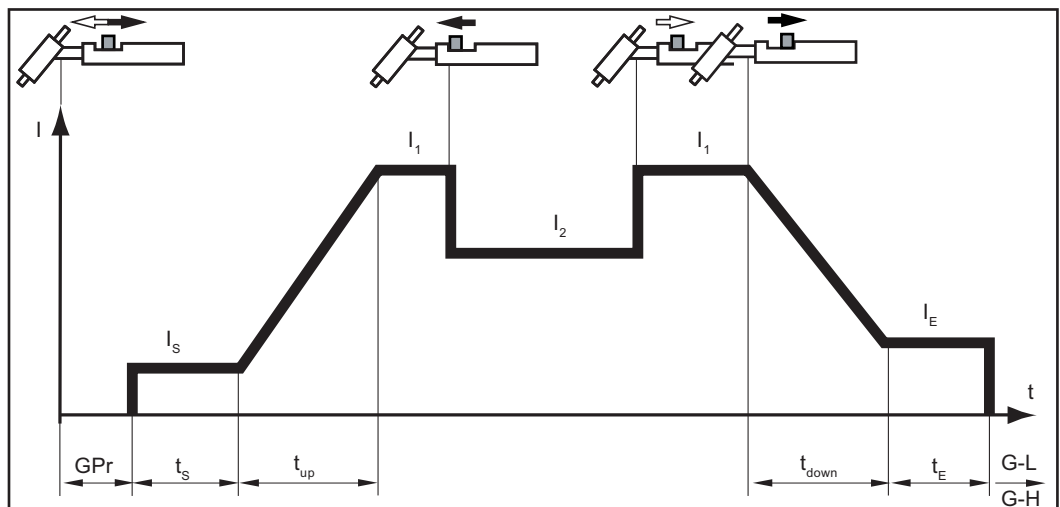

Special 4-step mode: variant 4

**Special 4-step mode:
variant 5**

Variant 5 of the special 4-step mode is activated when the SFS set-up parameter is set to "5".

Variant 5 allows the welding current to be increased and reduced without an up/down welding torch.

- The longer the torch trigger is held in the forward position during welding, the more the welding current increases (up to the maximum).
- The welding current remains constant when the torch trigger is released.
- The longer the torch trigger is pushed forward again, the more the welding current decreases.

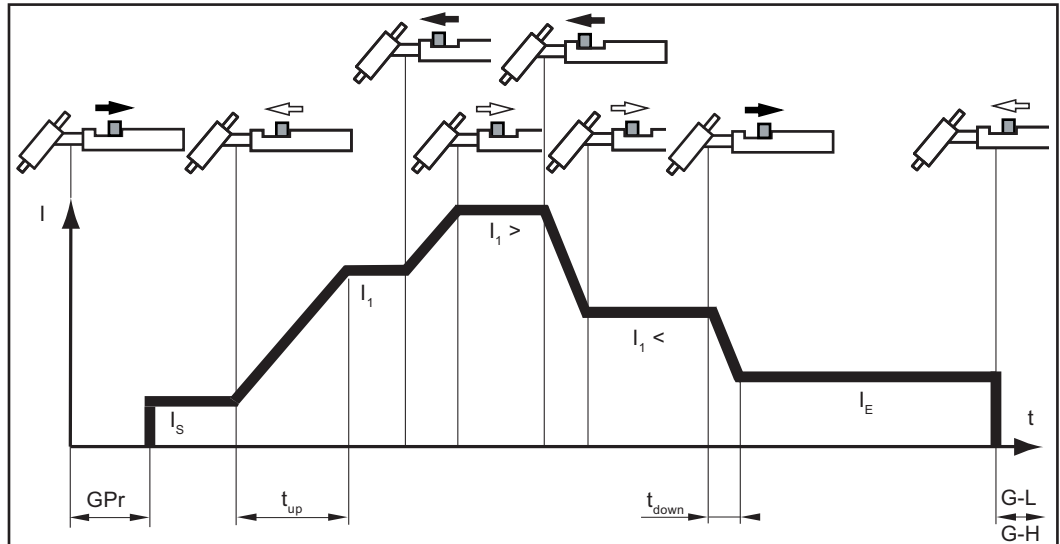

Special 4-step mode: variant 5

**Special 4-step mode:
variant 6**

Variant 6 of the special 4-step mode is activated when the SFS set-up parameter is set to "6".

- Welding start-up with starting current I_s and upslope: Pull back and hold the torch trigger
- Intermediate lowering to I_2 and changing from I_2 back to the main current I_1 : briefly press (< 0.5 s) and release the torch trigger
- End the welding process: press the torch trigger for longer (> 0.5 s) and release.

The process is automatically ended after the downslope phase and the final current phase.

If the torch trigger is pressed briefly (< 0.5 s) and released during either the downslope phase or the final current phase, then an upslope will take effect until it reaches the main current and the welding process will continue.

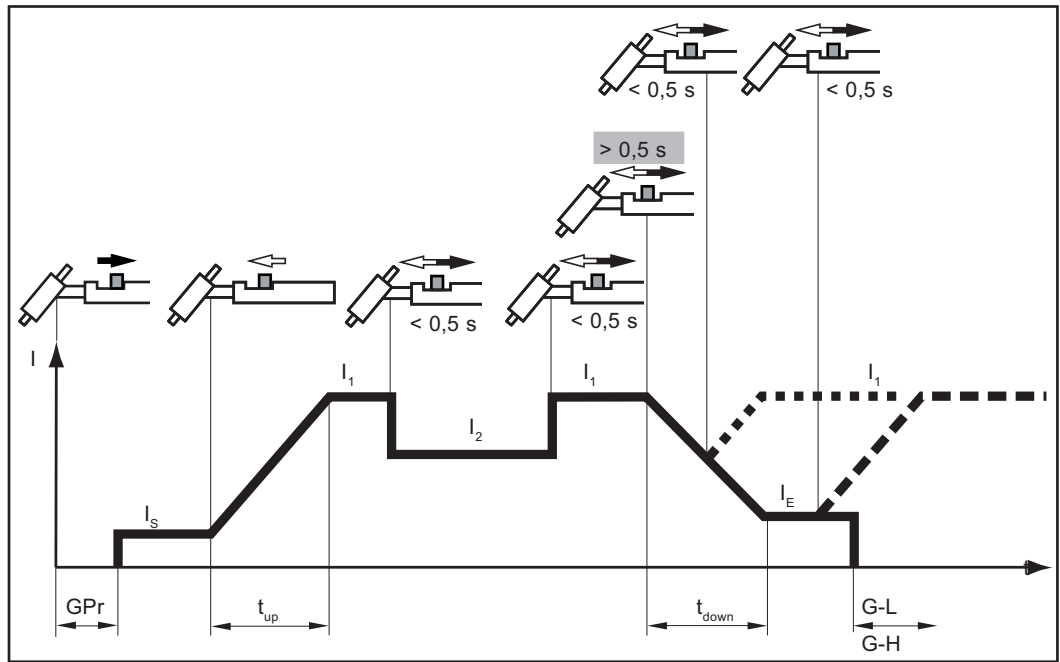

Special 4-step mode: variant 6

Cap shaping and cap overloading

Cap-shaping

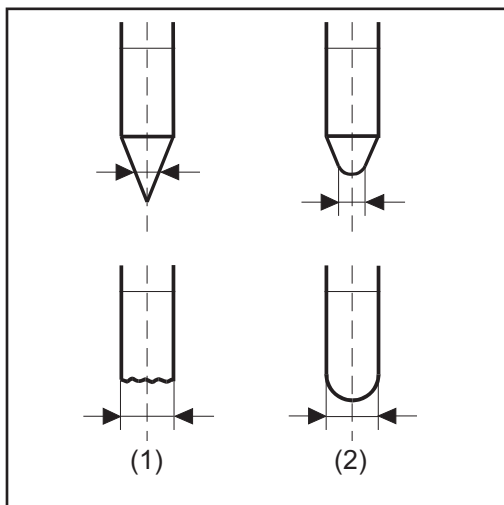

- (1) Before ignition
(2) After ignition

On MagicWave power sources, an automatic cap-shaping function is available for the TIG AC welding process:

- When the TIG AC welding process is selected, activate automatic cap-shaping
- The ideal cap for the specified diameter of the tungsten electrode is formed during welding start-up. A separate cap-shaping operation on a test workpiece is not necessary.
- The automatic cap-shaping function is then reset and deactivated. The automatic cap-shaping function has to be activated separately for each tungsten electrode.

NOTE!

The automatic cap-shaping function is not necessary if a sufficiently large cap has already formed at the tip of the tungsten electrode.

Cap overloading

If the cap is overloaded, there is a risk of an excessively large cap forming on the tungsten electrode. This will negatively affect the ignition properties.



If the cap is overloaded, the "Electrode overload" indicator will light up on the control panel.

Possible causes of cap overloading:

- tungsten electrode diameter is too small
- main current value I_1 set too high
- the balance has been set too far towards "+"

Remedy:

- use a tungsten electrode with a larger diameter
- reduce the main current and/or set the balance further towards "-"

NOTE!

The "Electrode overload" indicator is fine-tuned to work with the following tungsten electrodes:

TIG AC welding: pure tungsten electrodes

TIG DC welding: ceriated electrodes

For all other electrodes, the "Electrode overload" indicator must be treated as a reference value.

TIG welding

Safety



WARNING!

Danger from incorrect operation.

Possible serious injury and damage to property.

- ▶ Do not use the functions described here until you have read and completely understood these Operating Instructions.
 - ▶ Do not use the functions described here until you have fully read and understood all of the Operating Instructions for the system components, in particular the safety rules!
-



WARNING!

An electric shock can be fatal.

If the power source is connected to the mains electricity supply during installation, there is a high risk of very serious injury and damage.

- ▶ Before carrying out any work on the device make sure that the power source mains switch is in the "O" position
 - ▶ Before carrying out any work on the device make sure that the power source is unplugged from the mains
-

Welding parameters



Starting current I_S

Unit	%
Setting range	0 - 200% of main current I_1
Factory setting	35 AC, 50 DC

The starting current I_S is saved separately for the "TIG AC welding" and "TIG DC welding" modes.



UpSlope t_{up}

Unit	s
Setting range	0.0 - 9.9
Factory setting	0.5

The UpSlope t_{up} is saved separately for 2-step and 4-step modes.



Main current I₁

Unit	A	
Setting range	MW 1700 Job..... 3 - 170	TT 800 Job 0.5 - 80.0
	MW 2200 Job..... 3 - 220	TT 2200 Job ... 3 - 220
	MW 2500 Job..... 3 - 250	TT 2500 Job ... 3 - 250
	MW 3000 Job..... 3 - 300	TT 3000 Job ... 3 - 300
	MW 4000 Job..... 3 - 400	TT 4000 Job ... 3 - 400
	MW 5000 Job..... 3 - 500	TT 5000 Job ... 3 - 500
Factory setting	-	

IMPORTANT! On welding torches with the Up/Down function, the entire setting range can be selected while the device is idling. During welding, the main current can be corrected in steps of +/-20 A.



Reduced current I₂ (4-step mode)

Unit	% (of main current I ₁)
Setting range	0 - 100
Factory setting	50



DownSlope t_{down}

Unit	s
Setting range	0.01 - 9.9
Factory setting	1.0

The DownSlope t_{down} is saved separately for 2-step and 4-step modes.



Final current I_E

Unit	% (of main current I ₁)
Setting range	0 - 100
Factory setting	30



Balance (only on MagicWave for TIG AC welding process)

Unit	1
Setting range	-5 to +5
Factory setting	0

-5: highest fusing power, lowest cleaning action

+5: highest cleaning action, lowest fusing power



Wire speed (only on MW 4000/5000 and TT 4000/5000)
when cold wirefeeder option is available

Unit	m/min	ipm
Setting range	OFF / 0.1 - max.	OFF / 3.9 - max.
Factory setting	OFF	



Electrode diameter

Unit	mm	in.
Setting range	OFF - max.	OFF - max.
Factory setting	2.4	0.095

Preparation

- 1 Plug in the mains plug

CAUTION!

Risk of injury and damage from electric shock.

As soon as the mains switch is in the "I" position, the tungsten electrode of the welding torch is live.

- ▶ Ensure that the tungsten electrode does not touch any persons or electrically conductive or earthed parts (e.g. housing, etc.).

- 2 Move the mains switch to the "I" position

All the indicators on the control panel light up briefly.

TIG welding

- 1 Press the Mode button to select the required TIG mode:



2-step mode



4-step mode

- 2 Only with MagicWave: Press the Mode button to select the required TIG mode:



AC welding process



AC welding process with automatic cap-shaping function



DC welding process

- 3 Use the left or right parameter selection button to select the relevant welding parameters in the welding parameters overview
- 4 Use the adjusting dial to set the selected welding parameter to the required value

NOTE!

The wire speed parameter is available even though it is not shown on the welding parameters overview for the MW 1700/2200/2500/3000 and TT 2200/2500/3000 power sources.

Setting the wire speed parameter on MW 1700/2200/2500/3000 and on TT 2200/2500/3000

- a) Press the left parameter selection button until all the LEDs in the welding parameters overview go out



The m/min indicator on the units indicator lights up

- b) Use the adjusting dial to set the wire speed parameter to the required value
The value for the wire speed is displayed on the right-hand digital display.

All welding parameter set values that have been set using the adjusting dial remain stored until the next time they are changed. This applies even if the power source was switched off and on again in the interim.

- 5 Open the gas cylinder valve
- 6 Set the shielding gas flow rate:



Press the Gas-test button

The test gas flow lasts for a maximum of 30 seconds. Press the button again to stop the gas flow prematurely.

- Turn the adjusting screw on the underside of the pressure regulator until the manometer indicates the desired shielding gas flow rate
- 7** For long hosepacks and if condensation forms when the device is left unused in a cold environment:
pre-purge shielding gas - set the GPU setup parameter to a time value
- 8** Start welding (ignite the arc)

Igniting the arc

General

To ensure the best ignition sequence in the TIG AC welding process, the MagicWave power sources take account of:

- the diameter of the tungsten electrode
- the current temperature of the tungsten electrode with reference to the preceding welding and weld-off times

To ensure the ideal ignition sequence in TIG DC welding, MagicWave power sources are equipped with RPI (**R**everse **P**olarity **I**gnition).

At the start of welding, the polarity is briefly reversed. Electrons emerge from the workpiece and strike the tungsten electrode. This results in the tungsten electrode heating up rapidly - an essential prerequisite for optimum ignition properties.

For more information about the RPI function, please refer to the "Set-up menu DC: level 2" section in the set-up parameters chapter.

Igniting the arc using high frequency (HF ignition)

CAUTION!

Risk of injury due to shock caused by electric shock

Although Fronius devices comply with all relevant standards, high-frequency ignition can transmit a harmless but noticeable electric shock under certain circumstances.

- ▶ Use prescribed protective clothing, especially gloves!
- ▶ Only use suitable, completely intact and undamaged TIG hosepacks!
- ▶ Do not work in damp or wet environments!
- ▶ Take special care when working on scaffolding, work platforms, in forced positions (out-of-position welding), in tight, difficult to access or exposed areas!

HF ignition is activated when a time value has been set for the HFt setup parameter. The HF ignition indicator lights up on the control panel.

HF

Compared with touchdown ignition, HF ignition eliminates the risk of contamination of the tungsten electrode and the workpiece.

Procedure for HF ignition:

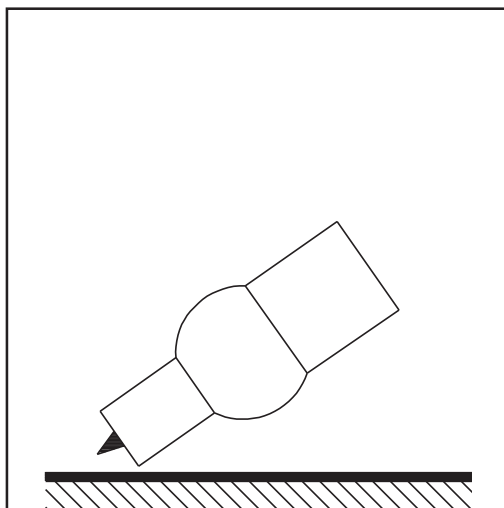

- 1 Place the gas nozzle down on the ignition location so that there is a gap of approx. 2 to 3 mm (5/64 to 1/8 in.) between the tungsten electrode and the workpiece

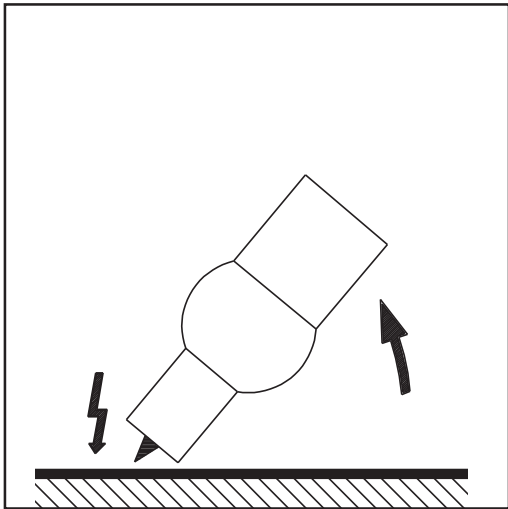

- 2 Increase the tilt angle of the torch and actuate the torch trigger according to the mode you have selected

The arc ignites without the electrode touching down on the workpiece.

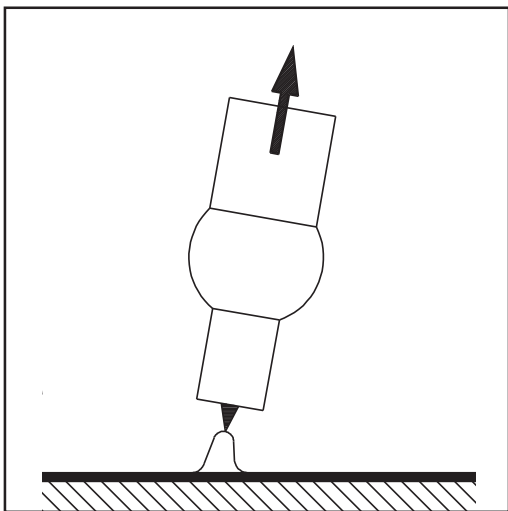

- 3 Tilt the torch back into the normal position
- 4 Carry out welding

Touchdown ignition

If the HFt setup parameter is set to OFF, HF ignition is deactivated. The welding arc is ignited by touching the workpiece with the tungsten electrode.

Procedure for igniting the arc using touchdown ignition:

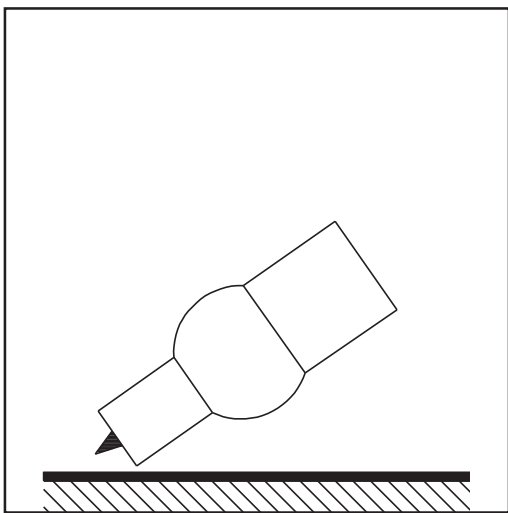

- 1 Place the gas nozzle down on the ignition location so that there is a gap of approx. 2 to 3 mm (5/64 to 1/8 in.) between the tungsten electrode and the workpiece

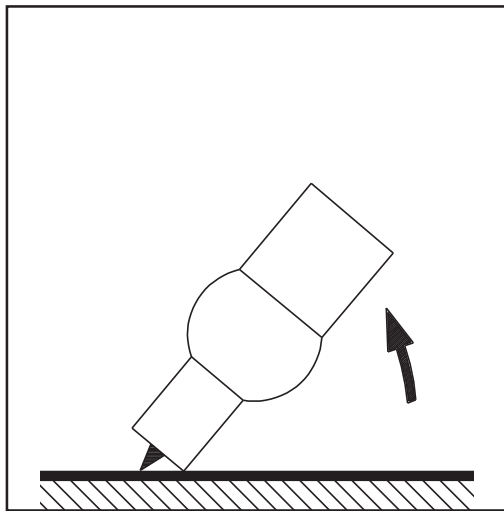

2 Actuate the torch trigger

Shielding gas flows.

3 Gradually tilt the welding torch up until the tungsten electrode touches the workpiece

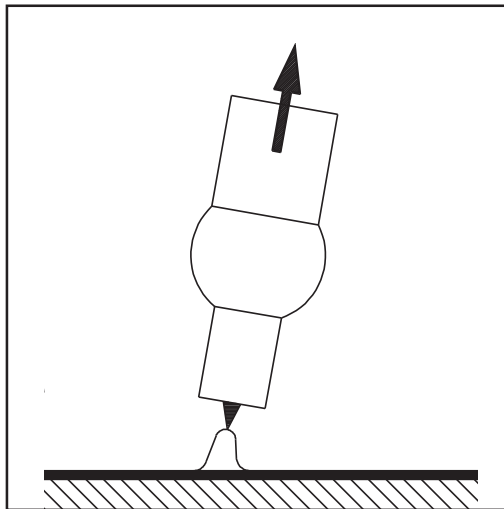

4 Raise the welding torch and move it into its normal position

The arc ignites.

5 Carry out welding

End of welding

1 Depending on the set mode, finish welding by releasing the torch trigger

2 Wait for the set gas post-flow and hold welding torch in position over the end of the weld seam

Special functions and options

Arc break watchdog function

If the arc breaks and the current does not start to flow again within the time specified in the set-up menu, the power source cuts out automatically. The service code "no | Arc" appears on the control panel.

To start the welding process again, press any key on the control panel or the torch trigger.

The settings for the arc break watchdog set-up parameter (Arc) are described in the "TIG set-up menu - level 2" section.

Ignition time-out function

The power source has an ignition time-out function.

Once the torch trigger is pressed, gas pre-flow begins immediately. Ignition then begins. If an arc does not appear within the time specified in the set-up menu, the power source cuts out automatically. The service code "no | IGn" appears on the control panel.

"E55" is displayed on the JobMaster TIG welding torch.

To try again, press any key on the control panel or press the torch trigger.

The settings for the ignition time-out parameter (ito) are described in the "TIG set-up menu: level 2" section.

TIG pulsing

The welding current set at the start of welding is not always ideal for the welding process as a whole:

- if the amperage is too low, the base material will not melt sufficiently,
- if overheating occurs, the liquid weld pool may drip.

The TIG pulsing function (TIG welding with pulsing welding current) offers a remedy: a low ground current I-G rises steeply to the significantly higher pulse current I1 and, depending on the set dcY (duty cycle) time, drops back to the ground current I-G. In TIG pulsing, small sections of the welding location melt quickly and then solidify again quickly.

In manual applications using TIG pulsing, the welding wire is applied in the maximum current phase (only possible in the low frequency range: 0.25 - 5 Hz). Higher pulse frequencies are mainly used in automatic mode to stabilise the arc.

TIG pulsing is used for out-of-position welding of steel pipes or when welding thin sheets.

Mode of operation of TIG pulsing when TIG DC welding is selected:

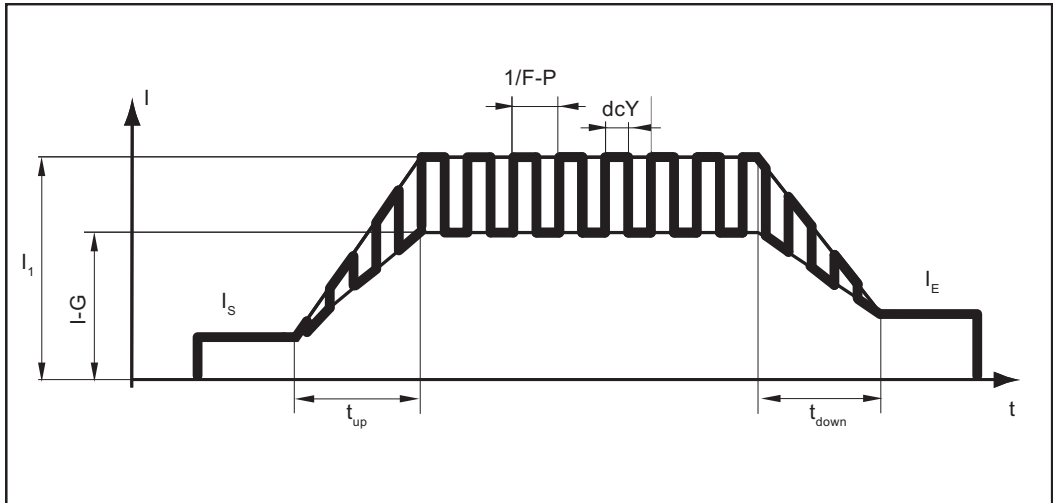

TIG pulsing - welding current curve

Legend:

I_S	Starting current	$F-P$	Pulse frequency *)
I_E	Final current	dcY	Duty cycle
t_{up}	Upslope	$I-G$	Ground current
t_{Down}	Downslope	I_1	Main current

*) ($1/F-P$ = time interval between two pulses)

Tacking function

The tacking function is available for the TIG DC welding process.

When a time period is specified for the tAC (tacking) setup parameter, the tacking function is assigned to 2-step mode and 4-step mode. The operating sequence of the modes remains unchanged.

During this period, a pulsed welding current is present that makes the weld pool run together better when two parts are being tacked.

Mode of operation of tacking function when the TIG DC welding process is selected:

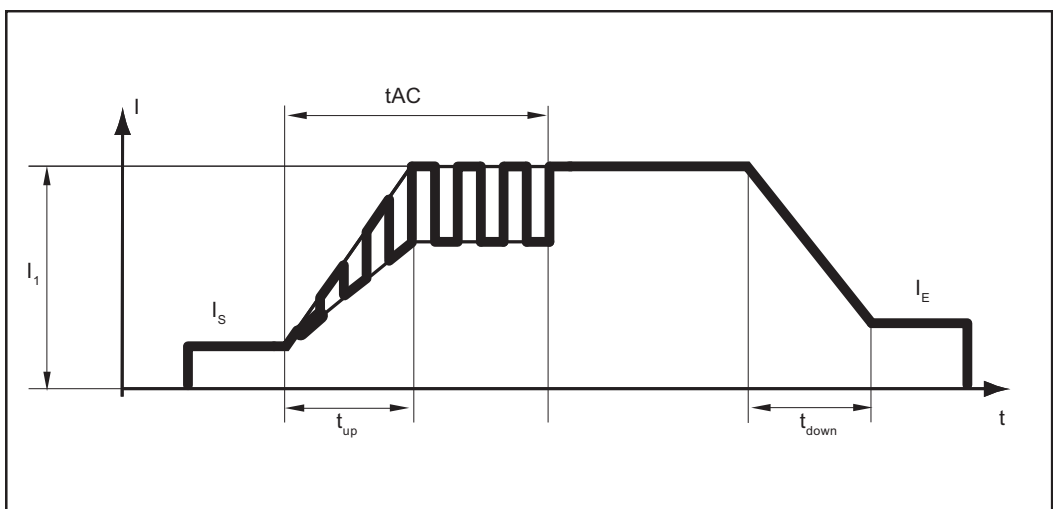

Tacking function - welding current curve

Legend:

tAC	Duration of pulsed welding current for the tacking process
I _S	Starting current
I _E	Final current
t _{up}	UpSlope
t _{Down}	DownSlope
I ₁	Main current

NOTE!

The following points apply to the pulsed welding current:

- ▶ The power source automatically regulates the pulsing parameters as a function of the specified main current I₁.
- ▶ There is no need to set any pulsing parameters.

The pulsed welding current begins

- after the end of the starting-current phase I_S
- With the UpSlope phase t_{up}

Depending on what tAC time has been set, the pulsed welding current may continue up to and including the final current phase I_E (tAC setup parameter set to "ON").

After the tAC time has elapsed, welding continues at a constant welding current, and any pulsing parameters that may have been set continue to be available.

NOTE!

To set a specified tacking time, the tAC setup parameter can be combined with the SPt setup parameter (spot welding time).

TIG cold-wire welding

TIG cold-wire welding is only possible in conjunction with a cold wire- feed unit.

Mode of operation of TIG cold-wire welding at a set pulse frequency when DC welding is selected:

- a) Current waveshape
- b) Wire feed speed curve

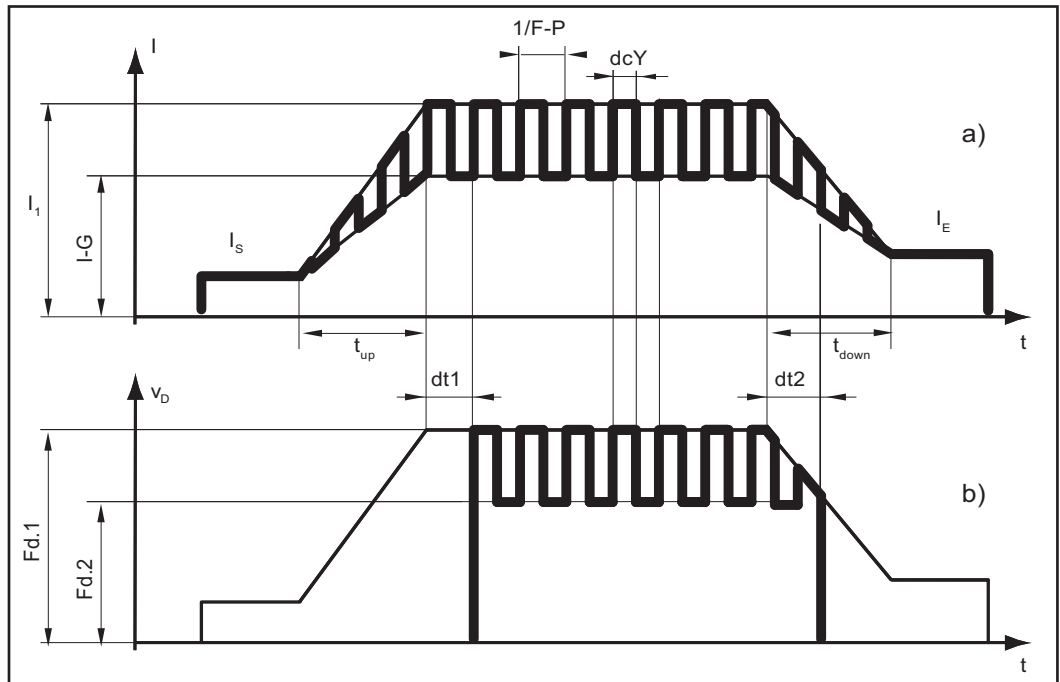

Legend:

I_s Starting current

I_E Final current

t_{up} Upslope

t_{Down} Downslope

$Fd.1$ Wire feed speed 1

$dt1$ Delay in the start of wirefeeding from the beginning of main current phase I_1

dcY Duty cycle

$I-G$ Ground current

I_1 Main current

$F-P$ Pulse frequency ¹⁾

$Fd.2$ Wire feed speed 2

$dt2$ Delay in the end of wirefeeding from the end of main current phase I_1

¹⁾ ($1/F-P$ = time interval between 2 pulses)

MMA welding

Safety



WARNING!

Danger from incorrect operation.

Possible serious injury and damage to property.

- ▶ Do not use the functions described here until you have read and completely understood these Operating Instructions.
- ▶ Do not use the functions described here until you have fully read and understood all of the Operating Instructions for the system components, in particular the safety rules!



WARNING!

An electric shock can be fatal.

If the power source is connected to the mains electricity supply during installation, there is a high risk of very serious injury and damage.

- ▶ Before carrying out any work on the device make sure that the power source mains switch is in the "O" position
- ▶ Before carrying out any work on the device make sure that the power source is unplugged from the mains

Preparation

- 1 Switch off cooling units (set setup parameter C-C to OFF)
- 2 Move the mains switch to the "O" position
- 3 Disconnect the mains plug
- 4 Remove the TIG welding torch
- 5 Plug the grounding cable in and latch it into place:
 - for MagicWave: in the grounding cable connection
 - for TransTig: in the (+) current socket
- 6 Use the other end of the grounding cable to establish a connection to the workpiece
- 7 Plug in the electrode cable and twist it clockwise to latch it into place:
 - for MagicWave: in the welding torch connection
 - for TransTig: in the (-) current socket
- 8 Plug in the mains plug



CAUTION!

Risk of injury and damage from electric shock.

As soon as the mains switch is in the "I" position, the rod electrode in the electrode holder is live.

- ▶ Make sure that the rod electrode does not touch any persons or electrically conductive or earthed parts (e.g. the housing, etc.).

- 9 Move the mains switch to the "I" position

All the indicators on the control panel light up briefly.

MMA welding

- 1 Press the Mode button to select:

 Manual metal arc welding mode

NOTE!

If the MMA welding mode is selected, the welding voltage will only be available after a 3-second delay.

2 Only for MagicWave: press the process button to select the required welding process:



MMA AC welding process



MMA DC- welding process



MMA DC+ welding process

NOTE!

The TransTig power source has no switchover facility between the MMA DC- and MMA DC+ welding processes.

Procedure with TransTig power source for switching from MMA DC- welding to MMA DC+ welding:

- a) Move the mains switch to the "O" position
- b) Disconnect the mains plug
- c) Reconnect the electrode holder and the grounding cable to the opposite current sockets (i.e. swap them over)
- d) Plug in the mains plug



CAUTION!

Risk of injury and damage from electric shock.

As soon as the mains switch is in the "I" position, the rod electrode in the electrode holder is live.

- ▶ Make sure that the rod electrode does not touch any persons or electrically conductive or earthed parts (e.g. the housing, etc.)

- e) Move the mains switch to the "I" position
All the indicators on the control panel will briefly light up

3 Select the desired welding current with the adjusting dial

The welding current value is displayed on the left-hand digital display.

NOTE!

All welding parameter set values that have been set using the adjusting dial remain stored until the next time they are changed.

This applies even if the power source was switched off and on again in the interim.

4 Start welding

Hotstart function

To obtain optimum welding results, it will sometimes be necessary to adjust the hotstart function.

Benefits

- Improved ignition, even when using electrodes with poor ignition properties
- Better fusion of the base material in the start-up phase, meaning fewer cold-shut defects
- Largely prevents slag inclusions

See the "Set-up menu: level 2" section for details on setting the available welding parameters.

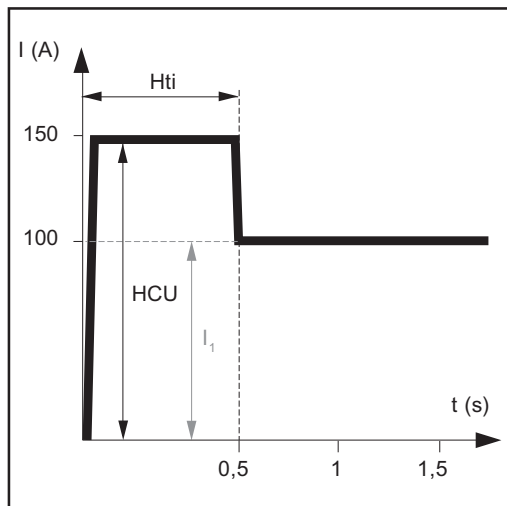

Example of hotstart function

Legend

Hti	Hot-current time, 0-2 s, factory setting: 0.5 s
HCU	HotStart current, 0-200%, factory setting 150%
I_1	Main current = set welding current

Function:

during the specified hot-current time (Hti), the welding current I_1 is increased to the HotStart current HCU.

To activate the hotstart function, the HotStart current HCU must be > 100 .

Settings examples:

HCU = 100

The HotStart current corresponds to the set welding current I_1 .
The hotstart function is not activated.

HCU = 170

The HotStart current is 70% higher than the set welding current I_1 .
The hotstart function is activated.

HCU = 200

The HotStart current is twice the set welding current I_1 .
The hotstart function is activated, the HotStart current is at its maximum.
 $HCU = 2 \times I_1$

Anti-stick function

As the arc becomes shorter, the welding voltage may drop so far that the rod electrode will tend to stick. This may also cause the rod electrode to burn out.

Electrode burn-out is prevented by activating the anti-stick function. If the rod electrode begins to stick, the power source immediately switches the welding current off. After the rod electrode has been detached from the workpiece, the welding process can be continued without any problems.

The anti-stick function can be activated and deactivated in the "Set-up menu - level 2" section.

Job mode

General

Job mode enhances the quality of welding engineering fabrication, both in manual and automated welding.

Up to 100 common jobs (operating points) can be reproduced in Job mode, avoiding the need to document welding parameters by hand.

Another advantage is that the power source is immediately ready for welding with the desired parameters. You can also arrange jobs in the order required by the production sequence. "Grouping" of jobs is also supported (e.g. by different components).

The result is to minimise downtimes while ensuring 100% reproducible quality.

Abbreviations

The following messages may be displayed while working with jobs:

- - - No job in this program location (job retrieval)

nPGNo job in this program location (when saving a job)

PrG There is a job in this program location

Pro Briefly displayed while job is being copied

dEL Briefly displayed while job is being deleted

Saving a job

NOTE!

Jobs are not created in the Job mode process.

Jobs can be created in the TIG AC welding, TIG DC welding and manual metal arc welding processes.

The device comes with no jobs pre-programmed. To create a job, proceed as follows:

- 1 Set the desired welding parameters that you want to store as a "Job".



NOTE!

All the settings that are active at that instant will be stored.

Exception: Power source specific settings in set-up menu - level 2

- 2 Briefly press the Store button to switch to the Job menu.
The first vacant program location for the job is shown.

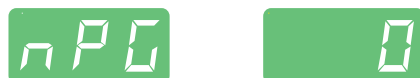

- 3 Select the desired program location with the adjusting dial, or leave the suggested program location unchanged.



- 4 Press and hold the Store button

NOTE!

If the selected program location already has a job stored in it, the existing job will be overwritten by the new one.
This action cannot be undone.

The left-hand digital display reads "Pro" - the job is stored in the program location you have just selected.



"PrG" appears on the left-hand digital display to indicate that the job is now saved.



- 5 Release the Store button
- 6 Briefly press the Store button to exit from the job menu.
The power source switches to the setting selected before the job was stored.



Retrieving a job

NOTE!

Before retrieving a job, make sure that the welding system has been installed and set up for the job.

- 1 **JOB** Using the Mode button, select Job mode.

The display shows the last job that was used.



- 2 Use the adjusting dial to select the desired job.



- To view the settings for this job, use the left and right parameter selection buttons. The settings cannot be modified.
- The mode and welding process (MagicWave) of the stored job are displayed.
- When you retrieve a job directly from the power source, you can also select vacant program locations (symbolised by "- -").

- 3 Start welding
Welding takes place with the welding parameters stored in the job. During welding you can switch to another job without stopping (e.g. in robot operation).
When you change to another welding process, Job mode ends.

Retrieving jobs on the JobMaster TIG

In Job mode, TIG jobs can also be selected using the JobMaster TIG welding torch.

Only program locations that have already been programmed can be selected using the JobMaster TIG welding torch. Thus related jobs can be grouped when they are saved by leaving a vacant program location after every job group.

When retrieving jobs using the JobMaster TIG welding torch, the Mode button (1) allows you to switch between the jobs in a group.

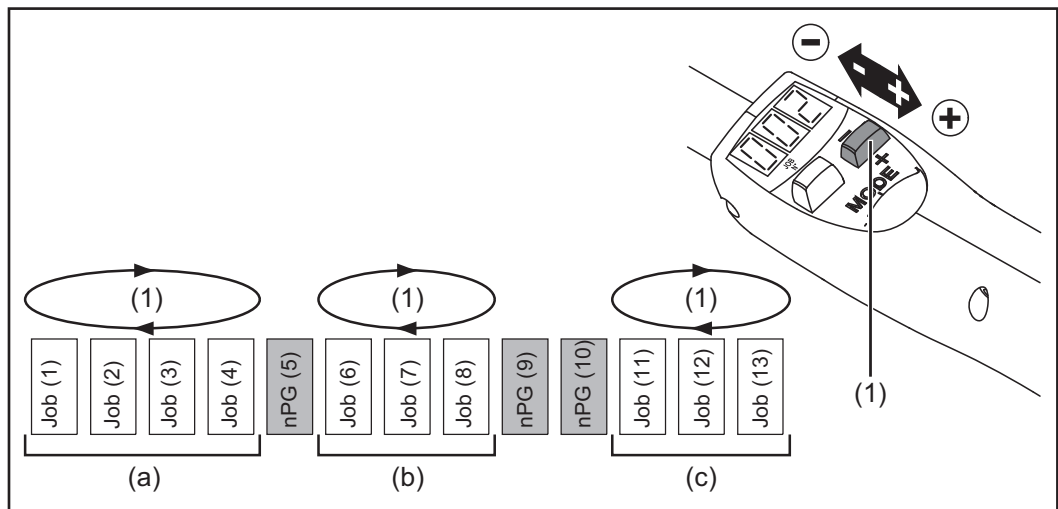

Example of job retrieval with the JobMaster TIG welding torch

Legend:

a) ... Group 1

b) ... Group 2

c) ... Group 3

To switch to another group of jobs using the JobMaster TIG welding torch:

- Press the parameter settings button (1) for longer than 2 s
- This switches to the next group up (or down)

NOTE!

It is not possible to change group while welding is in progress.

Copying/overwriting a job

In Job mode you can copy a job that has already been saved to one program location to any other program location. To copy a job, proceed as follows:

- 1 **JOB** Using the Mode button, select Job mode.

The display shows the last job that was used.



- 2 Use the adjusting dial to select the desired job.



- 3 Briefly press the Store button to change to the job menu.

The first vacant program location for the job to be copied is suggested



- 4 Select the desired program location with the adjusting dial, or leave the suggested program location unchanged.



- 5 Press and hold the Store button

NOTE!

If the selected program location already has a job stored in it, the existing job will be overwritten by the new one.

This action cannot be undone.

The left-hand digital display reads "Pro" - the job is copied to the program location you have just selected.



"PrG" appears on the left-hand digital display to indicate that the job has been copied.



- 6 Release the Store button
7 Briefly press the Store button to exit from the Job menu

The power source switches to the setting selected before the job was copied.

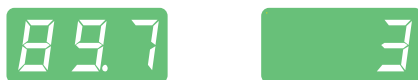

Deleting a job

Stored jobs can also be deleted again. To delete a job, proceed as follows:

- 1 Briefly press the Store button to switch to the Job menu.

The first vacant program location is shown.



- 2 Using the adjusting dial, select the job to be deleted (the "DEL" symbol lights up on the Gas test button).



- 3 Press and hold the Gas test "DEL" button.
The left-hand digital display reads "dEL" - the job is deleted.



"nPG" appears on the left-hand digital display to indicate that the job has been deleted.



- 4 Release the Gas test button
5 Briefly press the Store button to exit from the job menu.
The power source switches to the setting selected before the job was deleted

220

0.0

Setup settings

Job correction

General

In the Job correction menu, setup parameters can be adapted to the specific requirements of individual jobs.

Opening the Job correction menu



1 Using the Mode button, select "Job mode".



2 Press and hold the Store button



3 Press the Mode button

The power source is now in the Job correction menu. The first welding parameter, "Job", is shown. The "Job" parameter is used to select the job for which the welding parameters are to be adjusted.

Changing welding parameters



1 Turn the adjusting dial to select the job whose welding parameters you want to change



2 Use the left or right parameter selection button to select the welding parameter that you want to correct



3 Use the adjusting dial to change the welding parameter value

IMPORTANT! Any welding parameters that you change will be stored immediately and accepted as the valid parameters for the welding process.

Exiting the Job correction menu



1 Press the Store button

Welding parameters that can be corrected in the Job correction menu

NOTE!

Certain welding parameters apply specifically to the Job correction menu and relate, for example, to altering settings that were made on the control panel the first time the job was stored.

There is an explanation of each of these welding parameters in the following list, together with information about the setting ranges.

You can alter the following welding parameters for any stored job:

Eld		
Electrode Diameter		
Unit	mm	in.
Setting range	OFF - max.	OFF - max.
Factory setting	2,4	0.095

I-S

I (current)-Starting - Starting current I_S

Unit	% (of main current I_1)
Setting range	0 - 200
Factory setting	35

UPS

UpSlope t_{up} - time for the transition from the starting current I_S to the main current I_1

Unit	s
Setting range	0,0 - 9,9
Factory setting	0,5

I-1

I (current)-1 - main current I_1

Unit	A	
Setting range	MW 1700 Job.....3 - 170 MW 2200 Job.....3 - 220 MW 2500 Job.....3 - 250 MW 3000 Job.....3 - 300 MW 4000 Job.....3 - 400 MW 5000 Job.....3 - 500	TT 800 Job.....0.5 - 80.0 TT 2200 Job...3 - 220 TT 2500 Job...3 - 250 TT 3000 Job...3 - 300 TT 4000 Job...3 - 400 TT 5000 Job...3 - 500
Factory setting	-	

I-2

I (current)-2 - reduced current I_2 (only active in 4-step mode)

Unit	% (of main current I_1)
Setting range	0 - 100
Factory setting	50

dSL

DownSlope t_{down} - time for the transition from main current I_1 to final current I_E

Unit	s
Setting range	0,0 - 9,9
Factory setting	1,0

I-E

I (current)-End - Final current I_E

Unit	% (of main current I_1)
Setting range	0 - 100
Factory setting	30

JSL

Job Slope - For changing to another job during welding. "JSL" is the time that it takes for the welding current to adjust seamlessly from the present job to the next.

Unit	s
Setting range	OFF / 0.1 - 9.9
Factory setting	OFF

IMPORTANT! You can set the job slope "JSL" separately for each job that is stored.

NOTE!

Switching over from one job to the next without interrupting welding is only possible with a JobMaster TIG welding torch, robot interface or field bus.

GPr

Gas pre-flow time

Unit	s
Setting range	0 - 9,9
Factory setting	0,4

G-LGas-Low - gas post-flow time at minimum welding current
(minimum gas post-flow time)

Unit	s
Setting range	0 - 25
Factory setting	5

G-H

Gas-High - Increase in the gas post-flow time at maximum welding current

Unit	s
Setting range	0 - 40/Aut
Factory setting	Aut

For further information on the G-H parameter, see the TIG set-up menu.

tAC

Tacking function: Duration of the pulsed welding current at the start of tacking

Unit	s
Setting range	OFF / 0.1 - 9.9 / ON
Factory setting	OFF

For further information on the tAC parameter, see the TIG set-up menu.

F-P

Frequency-pulsing - Pulse frequency

Unit	Hz / kHz
Setting range	OFF / 0.20 Hz - 2.00 kHz
Factory setting	OFF

For further information on the F-P parameter, see the TIG set-up menu.

dcY

Duty cycle - The ratio of pulse duration to base current duration when a pulse frequency has been set

Unit	%
Setting range	10 - 90
Factory setting	50

I-G

I (current)-Ground - Ground current

Unit	% (of main current I_1)
Setting range	0 - 100
Factory setting	50

tri

trigger - Mode selection

Unit	-
Setting range	2t / 4t
	2t = 2-step mode
	4t = 4-step mode

Spt

Spot welding time

Unit	s
Setting range	OFF / 0.01 - 9.9
Factory setting	OFF

For further information on the Spt parameter, see the TIG set-up menu.

t-S

time-Starting - Starting current duration

Unit	s
Setting range	OFF / 0.01 - 9.9
Factory setting	OFF

For further information on the t-S parameter, see the TIG set-up menu.

t-E

time-End - Final current duration

Unit	s
Setting range	OFF / 0.01 - 9.9
Factory setting	OFF

For further information on the t-E parameter, see the TIG set-up menu.

POL

Polarity - Polarity of the welding current

Unit	-
Setting range	AC / nEG / POS
	AC = AC welding
	nEG = DC- welding
	POS = DC+ welding

ACF

AC frequency

Unit	Hz
Setting range	Syn / 40 - 250
Factory setting	60

For further information on the ACF parameter, see the AC / polarity reversal set-up menu.

Io
 AC current offset

Unit	%
Setting range	-70 to +70
Factory setting	0

For further information on the Io parameter, see the AC / polarity reversal set-up menu.

bAL

Balance - Relationship between fusing power and cleaning action

Unit	1
Setting range	-5 to +5
Factory setting	0
-5	= highest fusing power, lowest cleaning action
+5	= highest cleaning action, lowest fusing power

I-c

I (current) correction - I₁-correction range for job retrieval

Unit	%
Setting range	OFF / 1 - 100
Factory setting	OFF

IMPORTANT! The I₁ correction range only applies to job retrieval.

In the jobs, all the settings are permanently saved, i.e. cannot be changed. However, the welding parameter "I-c" permits subsequent correction of the main current I₁.

Example

The set-up parameter "I-c" has been set to 30%:

- The welding current I₁ can then be decreased or increased by up to 30%.

IMPORTANT! Every subsequent correction of the main current I₁ is reset (i.e. cancelled) when the power source is switched off.

Fd.1

Feeder 1 - wire feed speed 1 (cold wire-feed unit option)

Unit	m/min	ipm.
Setting range	OFF / 0.1 - max.	OFF / 3.94 - max.
Factory setting	OFF	OFF

Fd.2

Feeder 2 - wire feed speed 2 (cold wire-feed unit option)

Unit	m/min	ipm.
Setting range	OFF / 0.1 - max.	OFF / 3.94 - max.
Factory setting	OFF	OFF

For further information on the Fd.2 parameter, see the TIG set-up menu.

dYn

dynamic - arc force dynamic correction

Unit	-
Setting range	0 - 100
Factory setting	20

For further information on the dYn parameter, see the rod electrode set-up menu.

HCU

Hot-Start current

Unit	%
Setting range	0 - 200
Factory setting	150

dt1delay time 1 - time by which the start of wirefeeding is delayed after the beginning of main current phase I₁ (cold wire-feed unit option)

Unit	s
Setting range	OFF / 0.1 - 9.9
Factory setting	OFF

dt2delay time 2 - Delay in the end of wirefeeding from the end of main current phase I₁ (cold wire-feed unit option)

Unit	s
Setting range	OFF / 0.1 - 9.9
Factory setting	OFF

Fdi

Feeder inching - Feeder inching speed (cold wire-feed unit option)

Unit	m/min	ipm.
Setting range	1,0 - max.	39.37 - max.
Factory setting	5	197

Fdb

Feeder backward - wire withdrawal (cold wire-feed unit option)

Unit	mm	in.
Setting range	OFF / 1 - 50	OFF / 0.04 - 1.97
Factory setting	OFF	OFF

For further information on the Fdb parameter, see the TIG set-up menu.

The Setup menu

General

The set-up menu provides easy access to the knowledge base in the power source and to additional functions. The set-up menu can be used to make simple adjustments of the welding parameters to suit the various job settings.

- The Set-up menu contains all the set-up parameters that have an immediate effect on the welding process.
- Set-up menu - level 2 contains all the set-up parameters needed for making the preliminary settings on the welding machine.

The welding parameters are arranged in logical groups. Each of these groups is called up by pressing a different combination of buttons.

Overview

"The Set-up menu" is composed of the following sections:

- Protective gas shield set-up menu
- TIG set-up menu
- TIG set-up menu: level 2
- AC/polarity reversal set-up menu
- AC/polarity reversal set-up menu - level 2
- Rod electrode set-up menu
- Rod electrode set-up menu level 2
- Displaying welding circuit resistance r
- Displaying welding circuit inductivity L

Shielding gas setup menu

General

The Protective gas shield set-up menu provides easy access to the protective gas shield settings.

Opening the Protective gas shield set-up menu



1 Press and hold the Store button



2 Press the Gas test button

The power source is now in the Protective gas shield set-up menu. The last welding parameter selected is displayed.

Changing welding parameters



1 Use the left or right parameter selection button to select the welding parameter that you want to change



2 Use the adjusting dial to change the welding parameter value

Exiting the set-up menu



1 Press the Store button

Welding parameters in the Protective gas shield set-up menu

"Minimum" and "maximum" are used for setting ranges that differ according to power source, wire-feed unit, welding program, etc.

GPr

Gas pre-flow time

Unit	s
Setting range	0,0 - 9,9
Factory setting	0,4

G-L

Gas-Low - gas post-flow time at minimum welding current (minimum gas post-flow time)

Unit	s
Setting range	0 - 25
Factory setting	5

G-H

Gas-High - Increase in the gas post-flow time at maximum welding current

Unit	s
Setting range	0 - 40/Aut
Factory setting	Aut

The value set for G-H only applies if the maximum welding current actually has been set. The actual value is derived from the present welding current. For a medium welding current, for example, the actual value will be half of the value set for G-H.

IMPORTANT! The values set for the G-L and G-H set-up parameters are added together. For example, if both welding parameters are at maximum (25 s / 40 s), the gas post-flow will last:

- 25 s at minimum welding current
- 65 s at maximum welding current
- 37.5 s if the welding current is exactly half the maximum, etc.

If Aut is set, the gas post-flow time G-H is calculated automatically. This takes the selected process (AC or DC welding) into account.

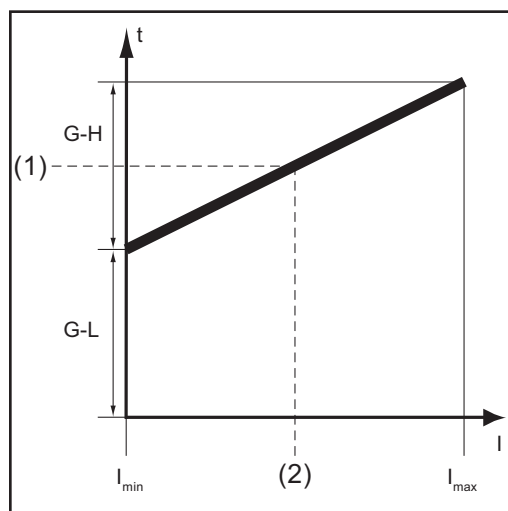

Legend:

- (1)... Gas post-flow time at any given moment
- (2)... Welding current at any given moment
- G-H... Post-flow I_{max}
- G-L ... Post-flow I_{min}

Gas post-flow time as a function of the welding current

GAS

Gasflow - set value for protective gas shield flow ("digital gas control" option)

Unit	l/min	cfh
Setting range	OFF / 5.0 - max.	OFF / 10.71 - max.
Factory setting	15	32.14

IMPORTANT! Please refer to "Digital Gas Control" instructions for more detailed explanations of "GAS" parameters.

GPU

Gas purger - protective gas shield purging

Unit	min
Setting range	OFF / 0.1 - 10.0
Factory setting	OFF

Purging of the protective gas shield begins as soon as a value is set for GPU. For safety reasons, purging of the protective gas shield cannot be restarted until a new GPU value is entered.

IMPORTANT! Purging of the protective gas shield is necessary if condensation forms when the device is left unused in a cold environment for a prolonged period. Long hose-packs are most affected.

TIG setup menu

Opening the TIG set-up menu



1 Press the Mode button to select 2-step mode or 4-step mode



2 Press and hold the Store button



3 Press the Mode button

The power source is now in the TIG set-up menu. The last welding parameter selected is displayed.

Changing welding parameters



1 Use the left or right parameter selection button to select the welding parameter that you want to change



2 Use the adjusting dial to change the welding parameter value

Exiting the set-up menu



1 Press the Store button

Welding parameters in the TIG set-up menu

"Minimum" and "maximum" are used for setting ranges that differ according to power source, wire-feed unit, welding program, etc.

SPT

Spot welding time

Unit	s
Setting range	OFF / 0.05 - 25.0
Factory setting	OFF

If a value has been set for the SPT set-up parameter, 2-step mode will have the function of the spot welding mode.

 The special spot welding indicator on the control panel remains lit as long as a value has been specified for the spot welding time.

tAC

Tacking function when TIG DC welding is selected: Duration of the pulsed welding current at the start of tacking

Unit	s
Setting range	OFF / 0.1 - 9.9 / ON
Factory setting	OFF
ON	The pulsed welding current remains in effect until the end of the tacking operation
0.1 - 9.9 s	The set time begins with the upslope phase. After the end of the pre-set time period, welding continues with a constant welding current; any pulsing parameters that have been set are available.
OFF	The tacking function is deactivated

TAC The special tacking indicator on the control panel remains lit as long as a value has been specified for the tacking time.

F-P

Frequency-pulsing - Pulse frequency

Unit	Hz / kHz
Setting range	OFF / 0.20 Hz - 2.00 kHz
Factory setting	OFF

The selected pulse frequency is also used for the reduced current I_2 .

IMPORTANT! If F-P is set to "OFF":

- the set-up parameters dcY, I-G and Fd.2 cannot be selected
- the wire feed speed set on the control panel is used for constant wirefeed at a constant welding current.

PI The special pulsing indicator on the control panel remains lit as long as a value has been specified for the pulse frequency.

Selecting the pulse frequency F-P:

0.2 Hz to 5 Hz	Thermal pulsing (out-of-position welding, automated welding)
1 kHz to 2 kHz	Arc-stabilising pulsing (stabilising the arc at a low welding current)

dcY

Duty cycle - The ratio of pulse duration to base current duration when a pulse frequency has been set

Unit	%
Setting range	10 - 90
Factory setting	50

I-G

I (current)-Ground - Ground current

Unit	% (of main current I_1)
Setting range	0 - 100
Factory setting	50

t-S

time-Starting - Starting current duration

Unit	s
Setting range	OFF / 0.01 - 9.9
Factory setting	OFF

The starting current time t-S specifies the duration of the starting-current phase I_S .

IMPORTANT! The t-S set-up parameter only applies to 2-step mode. In 4-step mode, the duration of the starting-current phase I_S is controlled using the torch trigger

t-E

time-End - Final current duration

Unit	s
Setting range	OFF / 0.01 - 9.9
Factory setting	OFF

The final current time t-E specifies the duration of the final current phase I_E .

IMPORTANT! The setup parameter t-E only applies to 2-step mode. In 4-step mode, the duration of the final current phase I_E is controlled with the torch trigger (see: "TIG operating modes").

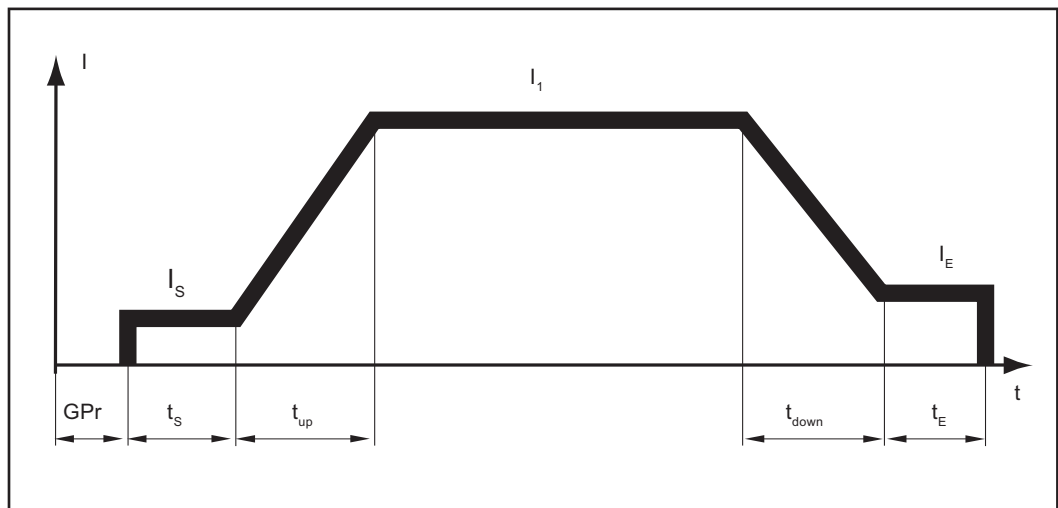

2-step mode: Starting and final current time

Legend:

GPr	Gas pre-flow time	I_1	Main current
I_S	Starting current	t_{down}	Downslope
t_S	Starting curr time	I_E	Final current
t_{up}	UpSlope	t_E	Final current time

Fd.2

Feeder 2 - wirefeed speed 2 (only where an optional cold wire-feed unit is connected)

Unit	m/min	ipm.
Setting range	OFF / 0.1 - max.	OFF / 3.94 - max.
Factory setting	OFF	OFF

If a different value is set for each of the set-up parameters Fd.2 and F-P, the wirefeed speed alternates between the values set for Fd.1 and Fd.2 according to the pulse frequency F-P of the welding current.

dt1

delay time 1 - time by which the start of wirefeeding is delayed after the beginning of main current phase I₁ (only where an optional cold wire-feed unit is connected)

Unit	s
Setting range	OFF / 0.1 - 9.9
Factory setting	OFF

dt2

delay time 2 - time by which the start of wirefeeding is delayed after the beginning of main current phase I₁ (only where an optional cold wire-feed unit is connected)

Unit	s
Setting range	OFF / 0.1 - 9.9
Factory setting	OFF

Fdb

Feeder backward - wire withdrawal (cold wire-feed unit option)

Unit	mm	in.
Setting range	OFF / 1 - 50	OFF / 0.04 - 1.97
Factory setting	OFF	OFF

IMPORTANT! Wire withdrawal prevents the welding wire from burning at the end. Before the welding current is switched off, the wire is withdrawn to the set value. A prerequisite for this function is that the arc has ignited.

FAC

Factory - for resetting the welding machine

Press and hold the Store button for 2 s to reset the machine to the factory settings. When the digital display shows "PrG", the welding system has been reset.

IMPORTANT! When the welding system is reset, all the personal settings in the set-up menu are lost. Jobs are not deleted when the welding machine is reset - these are preserved. Welding parameter settings in set-up menu - level 2 are not deleted.

2nd

set-up menu - level 2: second level of the set-up menu

TIG setup menu: level 2

Opening the TIG set-up menu: level 2



- 1 Opening the TIG set-up menu
- 2 Select "2nd" welding parameter
- 3 Press and hold the Store button
- 4 Press the Mode button

The power source is now in the TIG set-up menu - level 2. The last welding parameter selected is displayed.

Changing welding parameters



- 1 Use the left or right parameter selection button to select the welding parameter that you want to change
- 2 Use the adjusting dial to change the welding parameter value

Exiting the TIG set-up menu: level 2



- 1 Press the Store button
The power source is now in the TIG set-up menu
- 2 To exit from the TIG set-up menu, press the Store button again

Welding parameters in the TIG set-up menu - level 2

"Minimum" and "maximum" are used for setting ranges that differ according to power source, wirefeeder, welding program, etc.

SFS

Special 4-step mode

Unit	-	
Setting range	OFF / 1 - 6	
Factory setting	OFF	
	1 ... Variant 1	4 ... Variant 4
	2 ... Variant 2	5 ... Variant 5
	3 ... Variant 3	6 ... Variant 6

STS

Special two step - special 2-step mode for HF ignition after touching the workpiece

Unit	-
Setting range	OFF / 1
Factory setting	OFF

Ignition sequence, when the STS parameter is set to 1:

- Touch the workpiece with the tungsten electrode
- The short circuit detection on the power source is triggered
- Lift the tungsten electrode off
- After 300 ms the gas pre-flow time begins
- HF ignition is initiated
- End of welding due to arc break

C-C

Cooling unit control (option)

Unit	-
Setting range	Aut / ON / OFF
Factory setting	Aut
Aut	Cooling unit is switched off 2 minutes after the end of welding
ON	Cooling unit is ON all the time
OFF	Cooling unit is OFF all the time

IMPORTANT! If the cooling unit is provided with the optional "thermostat", the coolant return temperature is checked continuously. If the return temperature is less than 50 °C, the cooling unit is switched off automatically.

C-t

Cooling time - time from when the flow sensor is triggered until the "no | H2O" service code is output. For example, if there are air bubbles in the cooling system, the cooling unit will not cut out until the end of this preset time.

Unit	s
Setting range	5 - 25
Factory setting	10

IMPORTANT! Every time the power source is switched on, the cooling unit carries out a test run for 180 seconds.

HFt

High frequency time - high frequency ignition: Time interval between the HF pulses

Unit	s
Setting range	0.01 - 0.4 / OFF / EHF (start with external arc starters, e.g. plasma welding)
Factory setting	0.01

NOTE!

If there are problems with sensitive equipment in the immediate vicinity, increase the HFt parameter to a maximum of 0.4 s.

HF The special HF ignition indicator lights up on the control panel provided that a value has been specified for the HFt parameter.

If the HFt setup parameter is set to "OFF", no high frequency ignition takes place at the start of welding. In this case, welding starts with touchdown ignition.

 **CAUTION!**

Risk of injury due to shock caused by electric shock

Although Fronius devices comply with all relevant standards, high-frequency ignition can transmit a harmless but noticeable electric shock under certain circumstances.

- ▶ Use prescribed protective clothing, especially gloves!
- ▶ Only use suitable, completely intact and undamaged TIG hosepacks!
- ▶ Do not work in damp or wet environments!
- ▶ Take special care when working on scaffolding, work platforms, in forced positions (out-of-position welding), in tight, difficult to access or exposed areas!

Pri

Pre Ignition - delayed ignition with immediate high frequency start

Unit	s
Setting range	OFF / 0.1 - 1
Factory setting	OFF

If a time value is set for the parameter Pri, the welding arc is ignited with a delay corresponding to this value: Press the torch trigger - high frequency is activated for the specified duration - the welding arc is ignited

r

r (resistance) - welding circuit resistance (in mOhm)
see "Displaying welding circuit resistance r"

L

L (inductivity) - welding circuit inductivity (in microhenry)
see "Displaying welding circuit inductivity L"

Ito

Ignition time-out function - time until safety cut-out following an abortive ignition attempt

Unit	s
Setting range	0.1 - 9.9
Factory setting	5

IMPORTANT! The ignition time-out function is a safety function so cannot be deactivated. A description of the "Ignition time-out" function can be found in the section headed "TIG welding".

Arc

Arc - arc break watchdog: Time until safety cut-out following an arc break

Unit	s
Setting range	0.1 - 9.9
Factory setting	2

IMPORTANT! The arc break watchdog is a safety function and cannot be deactivated. A description of the arc break watchdog function can be found in the section "TIG welding".

SEt

Setting - Country-specific setting (Standard/USA) ... Std/US

Unit	-
Setting range	Std, US (Standard/USA)
Factory setting	Standard version: Std (measurements: cm/mm) USA version: US (measurements: inches)

E-P

External parameter - a user-defined welding parameter for the JobMaster TIG welding torch or robot interface (both optional).

A freely selectable welding parameter is available both on the JobMaster TIG welding torch and for the robot interface. If "E-P" has been selected, you can use the adjusting dial to choose between the following possibilities for this freely definable welding parameter:

OFF	No freely defined welding parameter has been assigned (factory setting)
ELd	Electrode diameter
bAL	Balance
SPt	Spot welding time
I-S	Starting current
UPS	UpSlope
I-2	Reduced current
dsl	DownSlope
I-E	Final current
ACF	AC frequency
F-P	Pulse frequency
dcY	Duty cycle
I-G	Base current
tAC	Tacking function: Duration of the tacking operation
Fd.1	Wire speed 1 (cold wirefeeder option)

The number of user-defined welding parameters depends on the configuration and the mode that has been selected.

ACS

Automatic current switch - automatic switchover to main current

Unit	-
Setting range	ON / OFF
Factory setting	ON
ON	The welding parameter I_1 (main current) will automatically be selected after welding has started. The main current I_1 can be set immediately.
OFF	The last selected welding parameter remains set during welding. The last selected welding parameter can be set immediately. No automatic selection of parameter I_1 takes place.

PPU

Select push-pull unit (cold wirefeeder option)

FCO

Feeder control - Wirefeeder cut-out (wire end sensor option)

Unit -

Setting range OFF/ON/noE

Factory setting OFF

OFF The power source halts the wirefeeder when the wire end sensor is triggered. "Err|056" appears on the display.

ON When the wire end sensor is triggered, the power source only halts the wirefeeder after the current weld seam has been completed. "Err|056" appears on the display.

noE The power source does not halt the wirefeeder when the wire end sensor is triggered. The wire end alarm is not displayed and is only transmitted to the robot control via the field bus.

IMPORTANT! The "noE" setting only functions in conjunction with the field bus applications. Robot interfaces ROB 4000/5000 do not support this function.

COR

Correction - Gas correction ("Digital gas control" option)

Unit -

Setting range AUT / 1.0 - 10.0

Factory setting Aut

IMPORTANT! Please refer to "Digital gas control" Operating Instructions for more detailed explanations of the "COR" parameter.

AC/polarity reversal set-up menu

General

This set-up menu is only available with MagicWave power sources.

Opening the AC/polarity reversal set-up menu



1 Press the Process button to select the AC welding process



2 Press and hold the Store button



3 Press the Process button

The power source is now in the AC/polarity reversal set-up menu. The last welding parameter selected is displayed.

Changing welding parameters



1 Use the left or right parameter selection button to select the welding parameter that you want to change



2 Use the adjusting dial to change the welding parameter value

Exiting the set-up menu



1 Press the Store button

Welding parameters in the AC/polarity reversal set-up menu

"Minimum" and "maximum" are used for setting ranges that differ according to power source, wire-feed unit, welding program, etc.

ACF

AC frequency

Unit

Hz

Setting range

Syn / 40 - 250

Factory setting

60

Syn

for mains synchronisation of two power sources for simultaneous AC welding.

IMPORTANT! In addition to the "Syn" setting, take account of the "PhA" parameter (phase adjustment in set-up menu - level 2 AC/polarity reversal).

Low frequency

soft, distant arc with shallow heat input

High frequency

focused arc with deep heat input

Io
AC current offset

Unit %

Setting range -70 to +70

Factory setting 0

+70 distant arc with shallow heat input

-70 narrow arc, deep heat input, faster welding speed

2nd
set-up menu - level 2: second level of the set-up menu

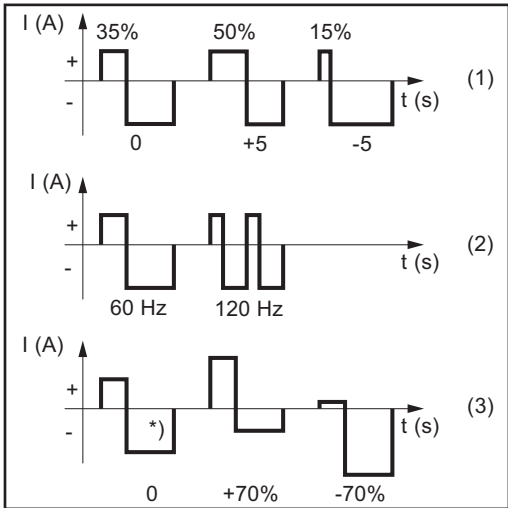

- (1) Balance
- (2) AC frequency
- (3) AC current offset
- *) Factory setting: 20% shift to the negative

Effect of the AC parameters on the wavelshape

AC/polarity reversal set-up menu - level 2

General

This set-up menu is only available with MagicWave power sources.

Opening the AC/polarity reversal set-up menu - level 2



- 1 Open the AC/polarity reversal set-up menu
- 2 Select "2nd" welding parameter

3 Press and hold the Store button

4 Press the Process button

The power source is now in the set-up menu - level 2 AC/polarity reversal. The last welding parameter selected is displayed.

Changing welding parameters



1 Use the left or right parameter selection button to select the welding parameter that you want to change

2 Use the adjusting dial to change the welding parameter value

Exiting from the AC/polarity reversal set-up menu - level 2



1 Press the Store button

The power source is now in the AC/polarity reversal set-up menu

2 To exit from the AC/polarity reversal set-up menu, press the Store button again

Welding parameters in the AC/polarity reversal set-up menu - level 2

"Minimum" and "maximum" are used for setting ranges that differ according to power source, wire-feed unit, welding program, etc.

PoS

Positive half wave

Unit

-

Setting range

tri / Sin / rEc / OFF

Factory setting

OFF

tri

Triangular waveform

Sin

Sine ... sinusoidal waveform (standard setting for a low-noise, stable arc)

rEc

Rectangular waveform with decreased edge steepness, for reducing noise levels compared to those that occur with the 100% rectangular waveform

OFF

100% rectangular waveform (stable but loud arc)

nEG

negative half-wave

Unit	-
Setting range	tri / Sin / rEc / OFF
Factory setting	OFF
tri	Triangular waveform
Sin	Sine ... sinusoidal waveform (standard setting for a low-noise, stable arc)
rEc	Rectangular waveform with decreased edge steepness, for reducing noise levels compared to those that occur with the 100% rectangular waveform
OFF	100% rectangular waveform (stable but loud arc)

PhA

Phase adjustment of the mains connection of two power sources for simultaneous AC welding.

Unit	-
Setting range	0 - 5
Factory setting	0

IMPORTANT! Before phase adjustment the "ACF" parameter must be set to "Syn" in the AC/polarity reversal set-up menu.

Phase adjustment takes place as follows:

- Prepare a test workpiece for simultaneous AC welding.
 - Adjust the PhA value on a power source to between 0 and 5 until the best welding result is achieved.
-

DC set-up menu

General

This set-up menu is only available with MagicWave power sources.

Opening the DC set-up menu



1 Press the Process button to select the DC welding process



2 Press and hold the Store button



3 Press the Process button

The power source is now in the DC set-up menu. The last welding parameter selected is displayed.

Changing welding parameters



1 Use the left or right parameter selection button to select the welding parameter that you want to change



2 Use the adjusting dial to change the welding parameter value

Exiting the set-up menu



1 Press the Store button

Welding parameters in the DC set-up menu

"Minimum" and "maximum" are used for setting ranges that differ according to power source, wire-feed unit, welding program, etc.

2nd

set-up menu - level 2: second level of the set-up menu

DC set-up menu - level 2

General

This set-up menu is only available with MagicWave power sources.

Opening the DC set-up menu - level 2



- 1 Open the DC set-up menu
- 2 Select "2nd" welding parameter

- 3 Press and hold the Store button

- 4 Press the Process button

The power source is now in the DC set-up menu - level 2. The last welding parameter selected is displayed.

Changing welding parameters



- 1 Use the left or right parameter selection button to select the welding parameter that you want to change

- 2 Use the adjusting dial to change the welding parameter value
-

Exiting from the DC set-up menu - level 2



- 1 Press the Store button

The power source is now in the DC set-up menu

- 2 To exit from the DC set-up menu, press the Store button again
-

Welding parameters in the DC set-up menu - level 2

"Minimum" and "maximum" are used for setting ranges that differ according to power source, wire-feed unit, welding program, etc.

rPI

Reversed polarity Ignition

Unit	-
Setting range	ON / OFF
Factory setting	OFF

IMPORTANT! The rPI ignition function

- is only available on the MagicWave power source
 - is not recommended for welding light-gauge sheets
-

Rod electrode setup menu

Opening the rod electrode set-up menu



1 Press the Mode button to select the MMA welding mode



2 Press and hold the Store button



3 Press the Mode button

The power source is now in the rod electrode set-up menu. The last welding parameter selected is displayed.

Changing welding parameters



1 Use the left or right parameter selection button to select the welding parameter that you want to change



2 Use the adjusting dial to change the welding parameter value

Exiting the set-up menu



1 Press the Store button

Welding parameters in the rod electrode set-up menu

"Minimum" and "maximum" are used for setting ranges that differ according to power source, wire-feed unit, welding program, etc.

HCU

HotStart current

Unit % (of main current I_1)

Setting range 0 - 200

Factory setting 150

Hti

Hot-current time

Unit s

Setting range 0 - 2,0

Factory setting 0,5

To obtain optimum welding results, it will sometimes be necessary to adjust the hotstart function.

Benefits:

- Improved ignition, even when using electrodes with poor ignition properties
- Better fusion of the base material in the start-up phase, meaning fewer cold-shut defects
- Largely prevents slag inclusions

dYn

dYn - arc force dynamic correction

Unit	-
Setting range	0 - 100
Factory setting	20
0	soft, low-spatter arc
100	harder, more stable arc

To obtain optimum welding results, it will sometimes be necessary to adjust the arc-force dynamic.

Functional principle:

at the instant of droplet transfer or when a short circuit occurs, there is a momentary rise in amperage. In order to obtain a stable arc, the welding current is temporarily increased. If the rod electrode threatens to sink into the weld pool, this measure prevents the weld pool solidifying, as well as preventing more prolonged short circuiting of the arc. This largely prevents the rod electrode from sticking.

FAC

Factory - Reset welding machine

- Press and hold the Store button for 2 s to reset the machine to the factory settings.
- When the digital display reads "PrG", the welding machine has been reset.

IMPORTANT! When the welding system is reset, all the personal settings in the set-up menu are lost. Jobs are not deleted when the welding machine is reset - these are preserved. Parameter settings in set-up menu - level 2 are not deleted.

2nd

set-up menu - level 2: second level of the set-up menu

Rod electrode setup menu: level 2

Opening the rod electrode set-up menu level 2



1 Open the rod electrode set-up menu

2 Select "2nd" welding parameter

3 Press and hold the Store button

4 Press the Mode button

The power source is now in the rod electrode set-up menu - level 2. The last welding parameter selected is displayed.

Changing welding parameters



1 Use the left or right parameter selection button to select the welding parameter that you want to change

2 Use the adjusting dial to change the welding parameter value

Exiting the rod electrode set-up menu - level 2



1 Press the Store button

The power source is now in the rod electrode set-up menu

2 To exit from the rod electrode set-up menu, press the Store button again

Welding parameters in the rod electrode setup menu - level 2

r
r (resistance) - welding circuit resistance (in mOhm)
see "Measuring the welding circuit resistance r"

L
L (inductivity) - Welding circuit inductivity (in microhenry)
see "Displaying welding circuit inductivity L"

ASt
Anti-stick

Unit	-
Setting range	ON / OFF
Factory setting	ON

As the arc becomes shorter, the welding voltage may drop so far that the rod electrode will tend to stick. This may also cause the rod electrode to burn out.

Electrode burn-out is prevented by activating the anti-stick function. If the rod electrode begins to stick, the power source immediately switches the welding current off. After the rod electrode has been detached from the workpiece, the welding process can be continued without any problems.

ELn

Electrode line - characteristic selection

Unit	1
Setting range	con or 0.1 - 20 or P
Factory setting	con

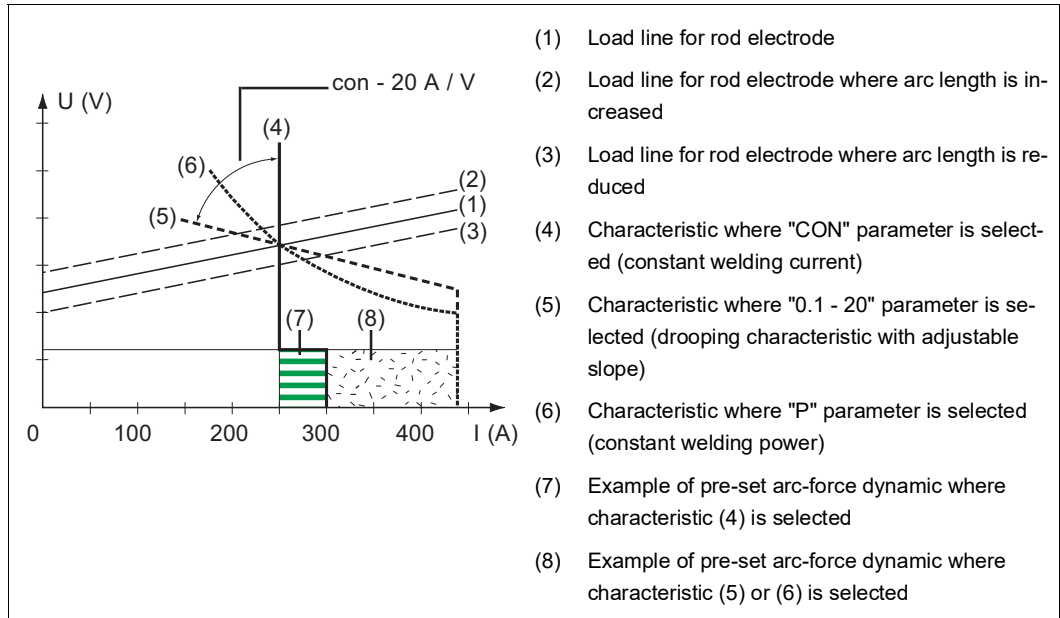

Characteristics that can be selected using the ELn function

"con" parameter (constant welding current)

- If the "con" parameter is set, the welding current will be kept constant, irrespective of the welding voltage. This results in a vertical characteristic (4).
- The "con" parameter is especially suitable for rutile electrodes and basic electrodes, as well as for arc air gouging.
- For arc air gouging, set the arc-force dynamic to "100".

Parameter "0.1 - 20" (drooping characteristic with adjustable slope)

- Parameter "0.1 - 20" is used to set a drooping characteristic (5). The setting range extends from 0.1 A / V (very steep) to 20 A / V (very flat).
- Setting a flat characteristic (5) is only advisable for cellulose electrodes.

NOTE!

When setting a flat characteristic (5), set the arc-force dynamic to a higher value.

"P" parameter (constant welding power)

- If the "P" parameter is set, the welding power is kept constant, irrespective of the welding voltage and welding current. This results in a hyperbolic characteristic (6).
- The "P" parameter is particularly suitable for cellulose electrodes.

NOTE!

If there are problems with a rod electrode tending to "stick", set the arc-force dynamic to a higher value.

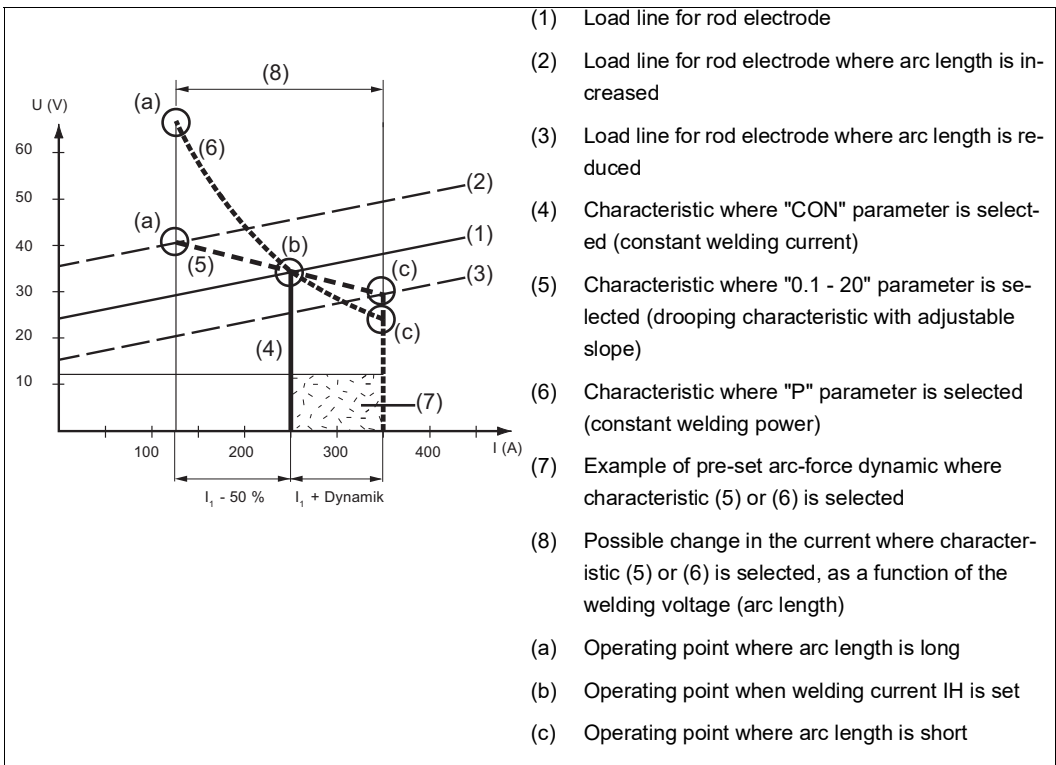

Settings example: $I_1 = 250 \text{ A}$, arc-force dynamic = 50

The characteristics (4), (5) and (6) shown here apply when using a rod electrode whose characteristic corresponds to the load line (1) at a given arc length.

Depending on what welding current (I) has been set, the point of intersection (operating point) of characteristics (4), (5) and (6) will be displaced along the load line (1). The operating point provides information on the actual welding voltage and the actual welding current.

Where the welding current (I_1) is permanently set, the operating point may migrate along the characteristics (4), (5) and (6) depending on the welding voltage at that moment in time. The welding voltage U is dependent upon the arc length.

If the arc length changes, e.g. in accordance with the load line (2), the resulting operating point will be the point where the corresponding characteristic (4), (5) or (6) intersects with the load line (2).

Applies to characteristics (5) and (6): Depending upon the welding voltage (arc length), the welding current (I) will also become either smaller or larger, even though the value set for I_1 remains the same.

Uco

U (Voltage) cut-off - Welding voltage limitation:

Unit	V
Setting range	OFF or 5 - 90
Factory setting	OFF

The arc length depends on the welding voltage. To end the welding process, it is usually necessary to significantly lift the rod electrode away from the workpiece. With the "Uco" parameter, the welding voltage can be limited to a value that makes it possible to end the welding operation simply by slightly lifting the rod electrode.

NOTE!

If, during welding, you often find that the welding operation is ended unintentionally, increase the value of the Uco parameter.

Measuring welding circuit resistance r

General

Measuring the welding circuit resistance "r" provides information on the overall resistance of the torch hosepack, welding torch, workpiece and grounding (earthing) cable.

If an increased welding circuit resistance is detected, e.g. after changing the torch, this may mean that the following components are faulty:

- Torch hosepack
- Welding torch
- Grounding (earthing) connection to the workpiece
- Grounding (earthing) cable

The calculated welding circuit resistance is displayed on the right-hand digital display.

r ... Welding circuit resistance (in mOhm)

Measuring the welding circuit resistance r

NOTE!

Make sure that the contact between the earthing clamp and the workpiece is on a cleaned section of the workpiece.

- 1 Make a grounding (earthing) connection to the workpiece
- 2 Open the TIG setup menu - level 2, or the rod electrode setup menu - level 2
- 3 Use the left or right welding parameter selection button to select the welding parameter "r"



NOTE!

Make sure that the contact between the electrode and the workpiece is on a cleaned section of the workpiece.

While the measurement is being performed, the cooling unit and the cold wirefeeder are deactivated.

- 4 Place the electrode fully on the surface of the workpiece
- 5 Briefly press the torch trigger or the Gas-test button
The welding circuit resistance is now calculated; during the measurement the right-hand digital display reads "run".



The measurement is finished when the welding circuit resistance is shown on the right-hand digital display (e.g. 11.4 milliohms)



Displaying welding circuit inductivity L

General information on welding circuit inductivity L

The way that the hosepack is arranged has a very significant effect on the weld properties. Particularly with pulsed-arc welding and AC welding, a high welding circuit inductivity may occur, depending on the length of the hosepack and on the way that it is arranged. The result is that the current rise is restricted.

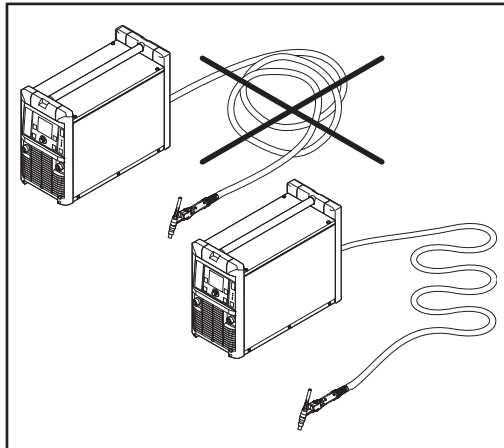

Correct arrangement of the hosepack

Changing the way the hosepack is arranged may help to improve the welding results. The hosepack must be laid out as shown in the illustration.

Displaying welding circuit inductivity L

- 1 Measure the welding circuit resistance r
- 2 Select the set-up parameter "L" using the left or right parameter selection button.
The right-hand digital display shows the welding circuit inductivity (e.g. 5 microhenrys)

Troubleshooting and maintenance

Troubleshooting

General

The digital power sources are equipped with an intelligent safety system. This means that apart from the fuse for the coolant pump, it has been possible to dispense with fuses entirely. After a possible malfunction or error has been remedied, the power source can be put back into normal operation again without any fuses having to be replaced.

Safety



WARNING!

Work that is carried out incorrectly may result in serious injury or damage to property.

- ▶ All the work described below must only be carried out by trained and qualified personnel.
- ▶ Do not carry out any of the work described below until you have fully read and understood this document.
- ▶ Do not carry out any of the work described below until you have fully read and understood all of the documents relating to the system components, in particular the safety rules.



WARNING!

An electric shock can be fatal.

Before starting the work described below:

- ▶ Turn the power source mains switch to the "O" position
- ▶ Disconnect the power source from the grid
- ▶ Ensure that the power source remains disconnected from the mains until all work has been completed
- ▶ After opening the device, use a suitable measuring instrument to check that electrically charged components (e.g. capacitors) have been discharged.



WARNING!

An inadequate ground conductor connection can cause serious injury or damage.

The housing screws provide a suitable ground conductor connection for earthing the housing.

- ▶ The housing screws must never be replaced with different screws unless a reliable ground conductor connection is established.

Displayed service codes

If any error message that is not described here appears on the displays, then the fault can only be fixed by After-Sales Service. Make a note of the error message shown in the display and of the serial number and configuration of the power source, and contact our After-Sales Service team with a detailed description of the error.

no | Prg

Cause: No preconfigured program has been selected

Remedy: Select a configured program

tP1 | xxx

Note: xxx stands for a temperature value

Cause: Overtemperature in the primary circuit of the power source

Remedy: Allow power source to cool down

tP2 | xxx

Note: xxx stands for a temperature value

Cause: Overtemperature in the primary circuit of the power source

Remedy: Allow power source to cool down

tP3 | xxx

Note: xxx stands for a temperature value

Cause: Overtemperature in the primary circuit of the power source

Remedy: Allow power source to cool down

tP4 | xxx

Note: xxx stands for a temperature value

Cause: Overtemperature in the primary circuit of the power source

Remedy: Allow power source to cool down

tP5 | xxx

Note: xxx stands for a temperature value

Cause: Overtemperature in the primary circuit of the power source

Remedy: Allow power source to cool down

tP6 | xxx

Note: xxx stands for a temperature value

Cause: Overtemperature in the primary circuit of the power source

Remedy: Allow power source to cool down

tS1 | xxx

Note: xxx stands for a temperature value

Cause: Overtemperature in the secondary circuit of the power source

Remedy: Allow power source to cool down

tS2 | xxx

Note: xxx stands for a temperature value

Cause: Overtemperature in the secondary circuit of the power source

Remedy: Allow power source to cool down

tS3 | xxx

Note: xxx stands for a temperature value

Cause: Overtemperature in the secondary circuit of the power source

Remedy: Allow power source to cool down

tSt | xxx

Note: xxx stands for a temperature value

Cause: Overtemperature in the power source control circuit

Remedy: Allow power source to cool down

Err | 049

Cause: Phase failure in power supply

Remedy: Check the mains fuse, the mains lead and the mains plug

Err | 050

Cause: Indirect symmetry error

Remedy: Contact After-Sales Service

Err | 051

Cause: Mains undervoltage: The mains voltage has dropped below the lower limit of the tolerance range (see section "Technical data")

Remedy: Check the mains voltage

Err | 052

Cause: Mains overvoltage: The mains voltage has exceeded the upper limit of the tolerance range (see section "Technical data")

Remedy: Check the mains voltage

no | IGn

Cause: "Ignition time-out" function is active; current did not start flowing before the length of wire specified in the set-up menu had been fed. The power source safety cut-out has tripped.

Remedy: Press the torch trigger repeatedly; clean the workpiece surface; if necessary, increase the time until the safety cut-out is triggered in the set-up menu: level 2

Err | PE

Cause: The earth current watchdog has triggered the safety cut-out of the power source.

Remedy: Switch off the power source, wait for 10 seconds and then switch it on again. If you have tried this several times and the error keeps recurring, contact After-Sales Service.

Err | IP

Cause: Primary overcurrent

Remedy: Contact After-Sales Service

Err | bPS

Cause: Fault in power module

Remedy: Contact After-Sales Service

dSP | Axx

Cause: Fault in the central control and regulation unit

Remedy: Contact After-Sales Service

dSP | Cxx

Cause: Fault in the central control and regulation unit

Remedy: Contact After-Sales Service

dSP | Exx

Cause: Fault in the central control and regulation unit
Remedy: Contact After-Sales Service

dSP | Sy

Cause: Fault in the central control and regulation unit
Remedy: Contact After-Sales Service

dSP | nSy

Cause: Fault in the central control and regulation unit
Remedy: Contact After-Sales Service

r | E30

Cause: r-calibration: there is no contact with the workpiece
Remedy: Connect up the grounding (earthing) cable; ensure a tight connection between the electrode and the workpiece

r | E31

Cause: r-calibration: procedure has been interrupted by repeated pressing of the torch trigger or Gas test button.
Remedy: Ensure a tight connection between the electrode and the workpiece
press the torch trigger or Gas test button once only

r | E33

Cause: r-calibration: poor contact between the tungsten electrode and the workpiece
Remedy: Clean the point of contact, check the earthing (grounding) connection

r | E34

Cause: r-calibration: poor contact between the tungsten electrode and the workpiece
Remedy: Clean the point of contact, check the earthing (grounding) connection

no | Arc

Cause: Arc break
Remedy: Press the torch trigger repeatedly; clean the surface of the workpiece

no | H2O

Cause: Cooling unit flow watchdog has been triggered
Remedy: Check the cooling unit; if necessary, top up the coolant or bleed the system as described in "Putting the cooling unit into service"

hot | H2O

Cause: Thermostat on cooling unit has tripped
Remedy: Wait until the end of the cooling phase, i.e. until "Hot | H2O" is no longer displayed.
ROB 5000 or field bus coupler for robot control: Before resuming welding, initialise the "Source error reset" signal.

-St | oP-

If the power source is being used with a robot interface or a field bus

Cause: Robot not ready
Remedy: Initialise "Robot ready" signal, initialise "Source error reset" signal (N.B. "Source error reset" only available in conjunction with ROB 5000 and field bus coupler for robot control)

**Power source -
troubleshooting**

Power source does not function

Mains switch is on, but indicators are not lit up

Cause: There is a break in the mains lead; the mains plug is not plugged in

Remedy: Check the mains lead, ensure that the mains plug is plugged in

Cause: Mains socket or mains plug faulty

Remedy: Replace faulty parts

Cause: Mains fuse protection

Remedy: Change the mains fuse protection

No welding current

Mains switch is ON, overtemperature indicator is lit up

Cause: Overload

Remedy: Check duty cycle

Cause: Thermostatic safety cut-out has tripped

Remedy: Wait until the power source automatically comes back on after the end of the cooling phase

Cause: The fan in the power source is faulty

Remedy: Contact After-Sales Service

No welding current

Mains switch is on, indicators are lit up

Cause: Grounding (earthing) connection is incorrect

Remedy: Check the grounding (earthing) connection and terminal for correct polarity

Cause: There is a break in the current cable in the welding torch

Remedy: Replace welding torch

Nothing happens when the torch trigger is pressed

Mains switch is on, indicators are lit up

Cause: The control plug is not plugged in

Remedy: Plug in the control plug

Cause: Welding torch or welding torch control line is faulty

Remedy: Replace welding torch

No protective gas shield

All other functions are OK

Cause: Gas cylinder is empty

Remedy: Change the gas cylinder

Cause: Gas pressure regulator is faulty

Remedy: Change the gas pressure regulator

Cause: Gas hose is not fitted or is damaged

Remedy: Fit or change the gas hose

Cause: Welding torch is faulty

Remedy: Change the welding torch

Cause: Gas solenoid valve is faulty

Remedy: Contact After-Sales Service

Poor weld properties

Cause: Incorrect welding parameters

Remedy: Check the settings

Cause: Grounding (earthing) connection is incorrect

Remedy: Check the grounding (earthing) connection and terminal for correct polarity

The welding torch becomes very hot

Cause: The dimensions of the welding torch are inadequate

Remedy: Observe the duty cycle and loading limits

Cause: Only on water-cooled machines: water flow is insufficient

Remedy: Check the water level, water flow rate, cleanliness, etc. If the coolant pump is blocked: use a screwdriver - placed on the bushing - to turn the coolant pump shaft

Cause: Only on water-cooled machines: C-C parameter is set to "OFF".

Remedy: In the set-up menu, set the C-C parameter to "Aut" or "ON".

Care, maintenance and disposal

General

Under normal operating conditions, the power source requires only a minimum of care and maintenance. However, it is vital to observe some important points to ensure it remains in a usable condition for many years.

Safety



WARNING!

Work that is carried out incorrectly may result in serious injury or damage to property.

- ▶ All the work described below must only be carried out by trained and qualified personnel.
- ▶ Do not carry out any of the work described below until you have fully read and understood this document.
- ▶ Do not carry out any of the work described below until you have fully read and understood all of the documents relating to the system components, in particular the safety rules.



WARNING!

An electric shock can be fatal.

Before starting the work described below:

- ▶ Turn the power source mains switch to the "O" position
- ▶ Disconnect the power source from the grid
- ▶ Ensure that the power source remains disconnected from the mains until all work has been completed
- ▶ After opening the device, use a suitable measuring instrument to check that electrically charged components (e.g. capacitors) have been discharged.



WARNING!

An inadequate ground conductor connection can cause serious injury or damage.

The housing screws provide a suitable ground conductor connection for earthing the housing.

- ▶ The housing screws must never be replaced with different screws unless a reliable ground conductor connection is established.

At every start-up

- Check mains plug, mains cable, welding torch, interconnecting hosepack and ground earth connection for damage
- Check that the device has an all-round clearance of 0.5 m (1 ft. 8 in.) around the device to ensure that cooling air can flow in and out freely

NOTE!

Air inlets and outlets must never be covered, not even partially.

Every 2 months

- If present: clean air filter

Every 6 months

 **CAUTION!**

Danger due to the effect of compressed air.

This can result in damage to property.

- ▶ Do not bring the air nozzle too close to electronic components.
-

- 1 Dismantle device side panels and clean inside of device with dry, reduced compressed air
- 2 If a lot of dust has accumulated, clean the cooling air ducts

 **WARNING!**

An electric shock can be fatal!

Risk of electric shock from improperly connected ground cables and equipment grounds.

- ▶ When reassembling the side panels, make sure that grounding cables and equipment grounds are properly connected.
-

Disposal

Dispose of in accordance with the applicable national and local regulations.

Appendix

Technical data

Special voltages



CAUTION!

An inadequately dimensioned electrical installation can cause serious damage.

- ▶ The mains lead and its fuse must be dimensioned accordingly.
The technical data shown on the rating plate applies.

MagicWave 1700 / 2200 Job

	MW 1700 Job	MW 2200 Job
Mains voltage	230 V	230 V
Mains voltage tolerance	-20 % / +15 %	-20 % / +15 %
Mains frequency	50/60 Hz	50/60 Hz
Mains fuse protection (slow-blow)	16 A	16 A
Mains connection ¹⁾	Restrictions possible	No restrictions
Primary continuous power (100% d.c. ²⁾)	3.3 kVA	3.7 kVA
Cos phi	0,99	0,99
Welding current range		
TIG	3 - 170 A	3 - 220 A
Electrode	10 - 140 A	10 - 180 A
Welding current at		
10 min/25 °C (77 °F) 40% d.c. ²⁾	170 A	220 A
10 min/25 °C (77 °F) 60% d.c. ²⁾	140 A	180 A
10 min/25 °C (77 °F) 100% d.c. ²⁾	110 A	150 A
10 min/40 °C (104 °F) 35% d.c. ²⁾	170 A	220 A
10 min/40 °C (104 °F) 60% d.c. ²⁾	130 A	170 A
10 min/40 °C (104 °F) 100% d.c. ²⁾	100 A	150 A
Open circuit voltage	88 V	88 V
Working voltage		
TIG	10.1 - 16.8 V	10.1 - 18.8 V
Electrode	20.4 - 25.6 V	20.4 - 27.2 V
Striking voltage (U _p)	9.5 kV	9.5 kV
The arc striking voltage is suitable for manual operation.		
Degree of protection	IP 23	IP 23
Type of cooling	AF	AF
Insulation class	B	B
EMC emission class (in accordance with EN/IEC 60974-10)	A	A
Dimensions L x W x H (with handle)	485 / 180 / 344 mm 19.1 / 7.1 / 13.6 in.	485 / 180 / 390 mm 19.1 / 7.1 / 15.4 in.
Weight (without handle)	14.6 kg 30.8 lb.	17.4 kg 38.3 lb.
Weight (with handle)	15 kg 33 lb.	17.8 kg 39.2 lb.
Mark of conformity	S, CE	S, CE

**MagicWave
2500 / 3000 Job**

	MW 2500 Job	MW 3000 Job
Mains voltage	3 x 400 V	3 x 400 V
Mains voltage tolerance	± 15 %	± 15 %
Mains frequency	50/60 Hz	50/60 Hz
Mains fuse protection (slow-blow)	16 A	16 A
Mains connection ¹⁾	Z _{max} at PCC ³⁾ = 122 mOhm	Z _{max} at PCC ³⁾ = 87 mOhm
Primary continuous power (100% d.c. ²⁾)	4.7 kVA	5.5 kVA
Cos phi	0,99	0,99
Welding current range		
TIG	3 - 250 A	3 - 300 A
Electrode	10 - 250 A	10 - 300 A
Welding current at		
10 min/40 °C (104 °F) 35% d.c. ²⁾	-	300 A
10 min/40 °C (104 °F) 40% d.c. ²⁾	250 A	-
10 min/40 °C (104 °F) 100% d.c. ²⁾	180 A	200 A
Open circuit voltage	89 V	89 V
Working voltage		
TIG	10.1 - 20.0 V	10.1 - 22.0 V
Electrode	20.4 - 30.0 V	20.4 - 32.0 V
Striking voltage (U _p)	10 kV	10 kV
The arc striking voltage is suitable for manual operation.		
Degree of protection	IP 23	IP 23
Type of cooling	AF	AF
Insulation class	B	B
EMC emission class (in accordance with EN/IEC 60974-10)	A	A
Dimensions L x W x H (with handle)	560 / 250 / 435 mm 22.0 / 9.8 / 17.1 in.	560 / 250 / 435 mm 22.0 / 9.8 / 17.1 in.
Weight	26.6 kg 58.64 lb.	28.1 kg 61.95 lb.
Mark of conformity	S, CE	S, CE

**MagicWave
2500 / 3000 Job
MV**

	MW 2500 Job MV	MW 3000 Job MV
Mains voltage	3 x 200 - 240 V 3 x 400 - 460 V 1 x 200 - 240 V	3 x 200 - 240 V 3 x 400 - 460 V 1 x 200 - 240 V
Mains voltage tolerance	± 10 %	± 10 %
Mains frequency	50/60 Hz	50/60 Hz
Mains fuse protection (slow-blow)		
3 x 400 - 460 V	16 A	16 A
3 x 200 - 240 V	32 A	32 A
1 x 200 - 240 V	32 A	32 A
Mains connection ¹⁾	Z _{max} at PCC ³⁾ = 122 mOhm	Z _{max} at PCC ³⁾ = 87 mOhm

	MW 2500 Job MV	MW 3000 Job MV
Primary continuous power (100% d.c. ²⁾)		
3 x 400 - 460 V	4.8 kVA	5.1 kVA
3 x 200 - 240 V	4.4 kVA	4.9 kVA
1 x 200 - 240 V	3.9 kVA	4.3 kVA
Cos phi	0,99	0,99
Welding current range (3-phase)		
TIG	3 - 250 A	3 - 300 A
Electrode	10 - 250 A	10 - 300 A
Welding current range (single phase)		
TIG	3 - 220 A	3 - 220 A
Electrode	10 - 180 A	10 - 180 A
Welding current at 3 x 400 - 460 V		
10 min/40 °C (104 °F) 35% d.c. ²⁾	-	300 A
10 min/40 °C (104 °F) 40% d.c. ²⁾	250 A	-
10 min/40 °C (104 °F) 100% d.c. ²⁾	180 A	190 A
Welding current at 3 x 200 - 240 V		
10 min/40 °C (104 °F) 30% d.c. ²⁾	-	300 A
10 min/40 °C (104 °F) 35% d.c. ²⁾	250 A	-
10 min/40 °C (104 °F) 100% d.c. ²⁾	160 A	180 A
Welding current at 1 x 200 - 240 V		
10 min/40 °C (104 °F) 40% d.c. ²⁾	220 A	-
10 min/40 °C (104 °F) 50% d.c. ²⁾	-	220 A
10 min/40 °C (104 °F) 100% d.c. ²⁾	150 A	160 A
Open circuit voltage	89 V	89 V
Working voltage		
TIG	10.1 - 20.0 V	10.1 - 22.0 V
Electrode	20.4 - 30.0 V	20.4 - 32.0 V
Striking voltage (U _p)	10 kV	10 kV
The arc striking voltage is suitable for manual operation.		
Degree of protection	IP 23	IP 23
Type of cooling	AF	AF
Insulation class	B	B
EMC emission class (in accordance with EN/IEC 60974-10)	A	A
Dimensions L x W x H (with handle)	560 / 250 / 435 mm 22.0 / 9.8 / 17.1 in.	560 / 250 / 435 mm 22.0 / 9.8 / 17.1 in.
Weight	28.2 kg 62.17 lb.	30 kg 66.14 lb
Mark of conformity	S, CE	S, CE

**MagicWave
4000 / 5000 Job**

	MW 4000 Job	MW 5000 Job
Mains voltage	3 x 400 V	3 x 400 V
Mains voltage tolerance	± 15 %	± 15 %
Mains frequency	50/60 Hz	50/60 Hz

	MW 4000 Job	MW 5000 Job
Mains fuse protection (slow-blow)	35 A	35 A
Mains connection ¹⁾	Restrictions possible	Restrictions possible
Primary continuous power (100% d.c. ²⁾)	15.5 kVA	17.9 kVA
Cos phi	0,99	0,99
Welding current range		
TIG	3 - 400 A	3 - 500 A
Electrode	10 - 400 A	10 - 440 A
Welding current at		
10 min/40 °C (104 °F) 40% d.c. ²⁾	-	500 A
10 min/40 °C (104 °F) 45% d.c. ²⁾	400 A	-
10 min/40 °C (104 °F) 60% d.c. ²⁾	365 A	440 A
10 min/40 °C (104 °F) 100% d.c. ²⁾	310 A	350 A
Open circuit voltage	90 V	90 V
Working voltage		
TIG	10.1 - 26.0 V	10.1 - 30.0 V
Electrode	20.4 - 36.0 V	20.4 - 37.6 V
Striking voltage (U _p)	9.5 kV	9.5 kV
The arc striking voltage is suitable for manual operation.		
Degree of protection	IP 23	IP 23
Type of cooling	AF	AF
Insulation class	F	F
EMC emission class (in accordance with EN/IEC 60974-10)	A	A
Dimensions L x W x H (with handle)	625 / 290 / 705 mm 24.6 / 11.4 / 27.8 in.	625 / 290 / 705 mm 24.6 / 11.4 / 27.8 in.
Weight	58.2 kg 128 lb.	58.2 kg 128 lb.
Mark of conformity	S, CE	S, CE

**MagicWave
4000 / 5000 Job
MV**

	MW 4000 Job MV	MW 5000 Job MV
Mains voltage	3 x 200 - 240 V 3 x 380 - 460 V	3 x 200 - 240 V 3 x 380 - 460 V
Mains voltage tolerance	± 10 %	± 10 %
Mains frequency	50/60 Hz	50/60 Hz
Mains fuse protection (slow-blow)	63/35 A	63/35 A
Mains connection ¹⁾	Restrictions possible	Restrictions possible
Primary continuous power (100% d.c. ²⁾)	13.9 kVA	16.5 kVA
Cos phi	0,99	0,99
Welding current range		
TIG	3 - 400 A	3 - 500 A
Electrode	10 - 400 A	10 - 440 A

	MW 4000 Job MV	MW 5000 Job MV
Welding current at		
10 min/40 °C (104 °F) 40% d.c. ²⁾	-	500 A
10 min/40 °C (104 °F) 45% d.c. ²⁾	400 A	-
10 min/40 °C (104 °F) 60% d.c. ²⁾	360 A	440 A
10 min/40 °C (104 °F) 100% d.c. ²⁾	300 A	350 A
Open circuit voltage	90 V	90 V
Working voltage		
TIG	10.1 - 26.0 V	10.1 - 30.0 V
Electrode	20.4 - 36.0 V	20.4 - 37.6 V
Striking voltage (U _p)	9.5 kV	9.5 kV
The arc striking voltage is suitable for manual operation.		
Degree of protection	IP 23	IP 23
Type of cooling	AF	AF
Insulation class	F	F
EMC emission class (in accordance with EN/IEC 60974-10)	A	A
Dimensions L x W x H (with handle)	625 / 290 / 705 mm 24.6 / 11.4 / 27.8 in.	625 / 290 / 705 mm 24.6 / 11.4 / 27.8 in.
Weight	60 kg 132.30 lb.	60 kg 132.30 lb.
Mark of conformity	S, CE, CSA	S, CE, CSA

TransTig 800 / 2200 Job

	TT 800 Job	TT 2200 Job
Mains voltage	230 V	230 V
Mains voltage tolerance	-20 % / +15 %	-20 % / +15 %
Mains frequency	50/60 Hz	50/60 Hz
Mains fuse protection (slow-blow)	16 A	16 A
Mains connection ¹⁾	Restrictions possible	No restrictions
Primary continuous power (100% d.c. ²⁾)	2.1 kVA	3.0 kVA
Cos phi	0,99	0,99
Welding current range		
TIG	0.5 - 80 A	3 - 220 A
Electrode	10 - 80 A	10 - 180 A
Welding current at		
10 min/25 °C (77 °F) 50% d.c. ²⁾	-	220 A
10 min/25 °C (77 °F) 60% d.c. ²⁾	-	200 A
10 min/25 °C (77 °F) 100% d.c. ²⁾	80 A	170 A
10 min/40 °C (104 °F) 40% d.c. ²⁾	-	220 A
10 min/40 °C (104 °F) 60% d.c. ²⁾	80 A	180 A
10 min/40 °C (104 °F) 100% d.c. ²⁾	70 A	150 A
Open circuit voltage	85 V	84 V
Working voltage		
TIG	10.0 - 13.2 V	10.1 - 18.8 V
Electrode	10.4 - 23.2 V	20.4 - 27.2 V

	TT 800 Job	TT 2200 Job
Striking voltage (U _p)	9.0 kV	9.5 kV
The arc striking voltage is suitable for manual operation.		
Degree of protection	IP 23	IP 23
Type of cooling	AF	AF
Insulation class	B	B
EMC emission class (in accordance with EN/IEC 60974-10)	A	A
Dimensions L x W x H (with handle)	485 / 180 / 344 mm 19.1 / 7.1 / 13.5 in.	485 / 180 / 390 mm 19.1 / 7.1 / 15.4 in.
Weight (without handle)	14.2 kg 31.3 lb.	16.4 kg 37 lb.
Weight (with handle)	- -	16.8 kg 37 lb.
Mark of conformity	S, CE	S, CE

**TransTig
2500 / 3000 Job**

	TT 2500 Job	TT 3000 Job
Mains voltage	3 x 400 V	3 x 400 V
Mains voltage tolerance	± 15 %	± 15 %
Mains frequency	50/60 Hz	50/60 Hz
Mains fuse protection (slow-blow)	16 A	16 A
Mains connection ¹⁾	Z _{max} at PCC ³⁾ = 172 mOhm	Z _{max} at PCC ³⁾ = 97 mOhm
Primary continuous power (100% d.c. ²⁾)	5.1 kVA	5.7 kVA
Cos phi	0,99	0,99
Welding current range		
TIG	3 - 250 A	3 - 300 A
Electrode	10 - 250 A	10 - 300 A
Welding current at		
10 min/40 °C (104 °F) 45% d.c. ²⁾	-	300 A
10 min/40 °C (104 °F) 50% d.c. ²⁾	250 A	-
10 min/40 °C (104 °F) 60% d.c. ²⁾	240 A	270 A
10 min/40 °C (104 °F) 100% d.c. ²⁾	210 A	230 A
Open circuit voltage	85 V	85 V
Working voltage		
TIG	10.1 - 20.0 V	10.1 - 22.0 V
Electrode	20.4 - 30.0 V	20.1 - 32.0 V
Striking voltage (U _p)	10 kV	10 kV
The arc striking voltage is suitable for manual operation.		
Degree of protection	IP 23	IP 23
Type of cooling	AF	AF
Insulation class	B	B
EMC emission class (in accordance with EN/IEC 60974-10)	A	A
Dimensions L x W x H (with handle)	560 / 250 / 435 mm 22.0 / 9.8 / 17.1 in.	560 / 250 / 435 mm 22.0 / 9.8 / 17.1 in.

	TT 2500 Job	TT 3000 Job
Weight	24.2 kg 53.35 lb.	24.2 kg 53.35 lb.
Mark of conformity	S, CE	S, CE

**TransTig
2500 / 3000 Job
MV**

	TT 2500 Job MV	TT 3000 Job MV
Mains voltage	3 x 200 - 240 V 3 x 400 - 460 V 1 x 200 - 240 V	3 x 200 - 240 V 3 x 400 - 460 V 1 x 200 - 240 V
Mains voltage tolerance	± 10 %	± 10 %
Mains frequency	50/60 Hz	50/60 Hz
Mains fuse protection (slow-blow)		
3 x 400 - 460 V	16 A	16 A
3 x 200 - 240 V	32 A	32 A
1 x 200 - 240 V	32 A	32 A
Mains connection ¹⁾	Z _{max} at PCC ³⁾ = 172 mOhm	Z _{max} at PCC ³⁾ = 97 mOhm
Primary continuous power (100% d.c. ²⁾)		
3 x 400 - 460 V	4.7 kVA	5.9 kVA
3 x 200 - 240 V	4.1 kVA	5.0 kVA
1 x 200 - 240 V	4.3 kVA	4.3 kVA
Cos phi	0,99	0,99
Welding current range (3-phase)		
TIG	3 - 250 A	3 - 300 A
Electrode	10 - 250 A	10 - 300 A
Welding current range (single phase)		
TIG	3 - 220 A	3 - 220 A
Electrode	10 - 180 A	10 - 180 A
Welding current at 3 x 400 - 460 V		
10 min/40 °C (104 °F) 45% d.c. ²⁾	-	300 A
10 min/40 °C (104 °F) 50% d.c. ²⁾	250 A	-
10 min/40 °C (104 °F) 100% d.c. ²⁾	200 A	240 A
Welding current at 3 x 200 - 240 V		
10 min/40 °C (104 °F) 35% d.c. ²⁾	-	300 A
10 min/40 °C (104 °F) 40% d.c. ²⁾	250 A	-
10 min/40 °C (104 °F) 100% d.c. ²⁾	180 A	210 A
Welding current at 1 x 200 - 240 V		
10 min/40 °C (104 °F) 50% d.c. ²⁾	220 A	-
10 min/40 °C (104 °F) 55% d.c. ²⁾	-	220 A
10 min/40 °C (104 °F) 100% d.c. ²⁾	190 A	190 A
Open circuit voltage	85 V	85 V
Working voltage		
TIG	10.1 - 20.0 V	10.1 - 22.0 V
Electrode	20.4 - 30.0 V	20.4 - 32.0 V
Striking voltage (U _p)	10 kV	10 kV
The arc striking voltage is suitable for manual operation.		

	TT 2500 Job MV	TT 3000 Job MV
Degree of protection	IP 23	IP 23
Type of cooling	AF	AF
Insulation class	B	B
EMC emission class (in accordance with EN/IEC 60974-10)	A	A
Dimensions L x W x H (with handle)	560 / 250 / 435 mm 22.0 / 9.8 / 17.1 in.	560 / 250 / 435 mm 22.0 / 9.8 / 17.1 in.
Weight	25.9 kg 57.10 lb.	25.9 kg 57.10 lb.
Mark of conformity	S, CE	S, CE

**TransTig
4000 / 5000 Job**

	TT 4000 Job	TT 5000 Job
Mains voltage	3 x 400 V	3 x 400 V
Mains voltage tolerance	± 15 %	± 15 %
Mains frequency	50/60 Hz	50/60 Hz
Mains fuse protection (slow-blow)	35 A	35 A
Mains connection ¹⁾	Restrictions possible	Restrictions possible
Primary continuous power (100% d.c. ²⁾)	11.8 kVA	15.1 kVA
Cos phi	0,99	0,99
Welding current range		
TIG	3 - 400 A	3 - 500 A
Electrode	10 - 400 A	10 - 500 A
Welding current at		
10 min/40 °C (104 °F) 40% d.c. ²⁾	-	500 A
10 min/40 °C (104 °F) 45% d.c. ²⁾	400 A	-
10 min/40 °C (104 °F) 60% d.c. ²⁾	365 A	450 A
10 min/40 °C (104 °F) 100% d.c. ²⁾	310 A	350 A
Open circuit voltage	86 V	86 V
Working voltage		
TIG	10.1 - 26.0 V	10.1 - 30.0 V
Electrode	20.4 - 36.0 V	20.4 - 40.0 V
Striking voltage (U _p)	9.5 kV	9.5 kV
The arc striking voltage is suitable for manual operation.		
Degree of protection	IP 23	IP 23
Type of cooling	AF	AF
Insulation class	F	F
EMC emission class (in accordance with EN/IEC 60974-10)	A	A
Dimensions L x W x H (with handle)	625 / 290 / 475 mm 24.6 / 11.4 / 18.7 in.	625 / 290 / 475 mm 24.6 / 11.4 / 18.7 in.
Weight	39.8 kg 87.7 lb.	39.8 kg 87.7 lb.
Mark of conformity	S, CE	S, CE

**TransTig
4000 / 5000 Job
MV**

	TT 4000 Job MV	TT 5000 Job MV
Mains voltage	3 x 200 - 240 V 3 x 380 - 460 V	3 x 200 - 240 V 3 x 380 - 460 V
Mains voltage tolerance	± 10 %	± 10 %
Mains frequency	50/60 Hz	50/60 Hz
Mains fuse protection (slow-blow)	63/35 A	63/35 A
Mains connection ¹⁾	Restrictions possible	Restrictions possible
Primary continuous power (100% d.c. ²⁾)	11.5 kVA	14.2 kVA
Cos phi	0,99	0,99
Welding current range		
TIG	3 - 400 A	3 - 500 A
Electrode	10 - 400 A	10 - 500 A
Welding current at		
10 min/40 °C (104 °F) 40% d.c. ²⁾	-	500 A
10 min/40 °C (104 °F) 45% d.c. ²⁾	400 A	-
10 min/40 °C (104 °F) 60% d.c. ²⁾	360 A	440 A
10 min/40 °C (104 °F) 100% d.c. ²⁾	300 A	350 A
Open circuit voltage	86 V	86 V
Working voltage		
TIG	10.1 - 26.0 V	10.1 - 30.0 V
Electrode	20.4 - 36.0 V	20.4 - 40.0 V
Striking voltage (U _p)	9.5 kV	9.5 kV
The arc striking voltage is suitable for manual operation.		
Degree of protection	IP 23	IP 23
Type of cooling	AF	AF
Insulation class	F	F
EMC emission class (in accordance with EN/IEC 60974-10)	A	A
Dimensions L x W x H (with handle)	625 / 290 / 475 mm 24.6 / 11.4 / 18.7 in.	625 / 290 / 475 mm 24.6 / 11.4 / 18.7 in.
Weight	42.0 kg 92.6 lb.	42.0 kg 92.6 lb.
Mark of conformity	S, CE, CSA	S, CE, CSA

**Explanation of
footnotes**

- 1) connected to public mains supply with 230 / 400 V and 50 Hz
- 2) D.C. = Duty cycle
- 3) PCC = interface to the public grid
- 4) TIG welding
- 5) MMA welding
- 6) An emission class A device is not designed for use in residential areas supplied with power from a public low-voltage grid.
The electromagnetic compatibility can be influenced by conducted or radiated radio frequencies.

Terms and abbreviations used

General

The terms and abbreviations listed here are used in connection with functions that are either included in the standard scope of supply or that are available as optional extras.

Terms and abbreviations A - C

ACF

AC frequency

ACS

Automatic current switch
Switchover to main current

Arc

Arc
Arc break watchdog

ASt

Anti-stick
For reducing the effect of a "sticking" rod electrode (MMA welding)

bAL

Balance
When "bAL" is selected for the external parameter "E-P", the balance on the JobMaster TIG welding torch can be adjusted.

C-C

Cooling unit control

COr

Correction
Gas correction; modification of the digital gas control to different protective gas shields (digital gas control option)

C-t

Cooling time
Time from when the flow watchdog is triggered until the "no | H2O" service code is output.

Terms and abbreviations D - E

dcY

duty cycle
Ratio of pulse duration to base current duration (in TIG AC welding)

dt1

delay-time 1
Wirefeed start delay time (only where an optional cold wire-feed unit is connected)

dt2

delay-time 2
Wirefeed end delay time (only where an optional cold wire-feed unit is connected)

dYn

dynamic
Arc force dynamic correction for standard arcs, pulse correction for pulsed arcs or correction of various welding parameters in CMT (job correction or arc force dynamic and pulse correction settings in the set-up menu for the Standard control panel)

Eld

Electrode diameter

When "Eld" is selected for the external parameter "E-P", the electrode diameter on the JobMaster TIG welding torch can be adjusted.

ELn

Electrode line

Characteristic selection (MMA welding)

E-P

External parameter

Freely selectable welding parameter for the JobMaster TIG welding torch

Terms and abbreviations F**FAC**

Factory

Reset welding machine

FCO

Feeder control

Wire-feed unit cut-out (wire end sensor option)

Fd.1

Feeder1

Wire feed speed 1 (only where an optional cold wire-feed unit is connected)

Fd.2

Feeder2

Wire feed speed 2 (only where an optional cold wire-feed unit is connected)

Fdb

Feeder backward

Withdraws wire to prevent it from being burned at the welding end (cold wire-feed unit option).

Fdi

Feeder inching

Feeder inching speed

F-P

Frequency-Pulse

Pulse frequency

Terms and abbreviations G - H**GAS**

Gasflow

Set value for protective gas shield flow

G-H

Gas post-flow time high

Gas post-flow time at maximum welding current

G-L

Gas post-flow time low

Gas post-flow time at minimum welding current

GPR

Gas pre-flow time

GPU

Gas purger

HCU
Hot-start current
(MMA welding)

HFt
High frequency time
High frequency ignition

Hti
Hot-current time
(MMA welding)

Terms and abbreviations I - P

I-E
I (current) - End
Final current

I-G
I (current) - Ground
Ground current

Io
AC current offset

I-S
I (current) - Starting
Starting current

Ito
Ignition time-out

L
L (inductivity)
Displays welding circuit inductivity

nEG
negative
Negative half-wave (TIG AC welding)

PhA
Phase Adjustment
Phase adjustment of the mains connection of two power sources for simultaneous AC welding

Pos
Positive
Positive half-wave (TIG AC welding)

Pri
Pre Ignition - delayed high frequency ignition

PPU
Push-pull unit
For selecting and calibrating the connected push-pull unit

Terms and abbreviations R - 2nd

r
r (resistance)
Determine welding circuit resistance

rPi
reverse polarity ignition

SEt
Setting
Country-specific setting (Standard / USA)

SFS

Special four-step mode

Spt

Spot welding time

STS

Special Two Step

Special 2-step mode for HF ignition after touching the workpiece

tAC

Tacking function

t-E

time - End current

Final current duration

t-S

time - Starting current

Starting current duration

Uco

U (Voltage) cut-off

Welding voltage limitation during MMA welding Makes it possible to stop the welding process by slightly raising the rod electrode.

2nd

Second level of set-up menu

FRONIUS INTERNATIONAL GMBH

Froniusstraße 1
A-4643 Pettenbach
AUSTRIA
contact@fronius.com
www.fronius.com

Under **www.fronius.com/contact** you will find the addresses
of all Fronius Sales & Service Partners and locations.



Find your
spareparts online



spareparts.fronius.com